

# MEGA 8



WATER FILTRATION AND DISINFECTION SYSTEM

USER MANUAL (Please read carefully before proceeding and retain for future use)



Thank you for purchasing a Rainfresh product  
We are committed to ensuring that you are **totally satisfied**.

If you have any questions or concerns while installing, operating or maintaining your new system, **please contact us !**

<p><b>QUESTIONS?</b></p>	<p> Canada Toll Free <b>1800 667 8072</b> Toronto and Area <b>(905) 884 9388</b>  (Monday to Friday 8:00 AM to 5:00 PM EST)</p>	<p> <b>info@rainfresh.ca</b></p>	<p> <b>www.rainfresh.ca</b></p>
--------------------------	--	--	--

## CONTENTS

A. Introduction .....	2
B. Safety Instructions .....	2
C. Water Quality Requirements.....	3
D. Installation .....	3
E. Disinfection Procedure.....	6
F. Ballast Features.....	7
G. Operation and Maintenance .....	7
a. Winterizing the system .....	9
H. Troubleshooting.....	9
I. Technical Specifications .....	9
J. Parts List .....	10
K. Warranty.....	10



Tested and certified by CSA Group to CSA Standard B483.1, to NSF/ANSI Standard 61 for material and structural requirements only, and to NSF/ANSI 372 for lead-free requirements

Additional testing and verification for UV dose performed by independent laboratory.

## (A) INTRODUCTION

Rainfresh MEGA8 system makes water safe to drink by instantly destroying pathogenic bacteria (such as coliforms, E. coli, viruses etc.). It also reduces sediment, chlorine, bad tastes and odours. MEGA8 utilizes the proven disinfection properties of ultraviolet light (UV) emitted at 254 nm wavelength. UV systems are used by many municipalities in Canada and around the world as a primary disinfectant as it is a natural, non-chemical, environmentally safe technique that does not form any harmful disinfection by-products.

MEGA8 features a 3-stage design. The first stage is a 5 micron sediment filter that reduces dirt, rust, sand and other fine particulate matter. The second stage is an activated carbon block filter that reduces chlorine, taste and odour by >95%. The 3<sup>rd</sup> and final stage is a UV system that instantly destroys bacteria & viruses in the water using germicidal ultraviolet light emitted by a specially engineered UV lamp. Treated water flows out of the chamber and is ready for consumption. See Fig. 1

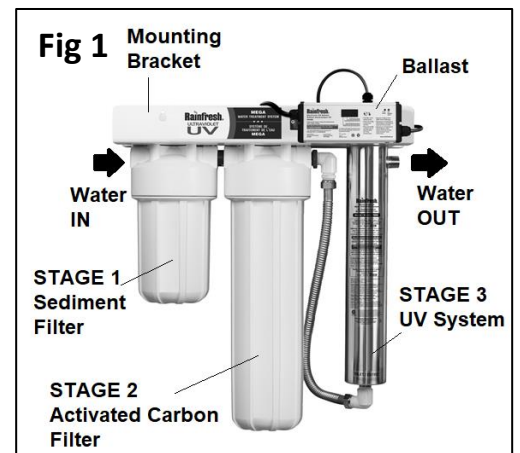

## (B) SAFETY INSTRUCTIONS

Hg

Contains mercury

- UV Lamp contains mercury (Hg).
- Dispose or recycle in accordance with applicable laws.
- For information on safe handling procedures and safe disposal and recycling, consult :  
<https://www.canada.ca/en/environment-climate-change/campaigns/diverting-mercury-light-bulbs.html>  
<https://www.canada.ca/en/environment-climate-change/services/canadian-environmental-protection-act-registry/guidelines-objectives-codes-practice/sound-management-lamps-containing-mercury.html#toc12>

- **WARNING: DO NOT LOOK DIRECTLY AT UV LAMP WHEN LAMP IS ON.** UV light can cause serious burns to eyes & skin.
- **WARNING:** Do not operate the UV lamp outside the UV disinfection chamber.
- To comply with the National Electrical Code and to provide additional protection from the risk of electric shock, this system should only be connected to a properly grounded, grounding-type controller receptacle that is protected by a Ground Fault Circuit Interrupter (GFCI).
- Installation of the UV disinfection system and water filter may interrupt electrical grounding continuity of your plumbing system. For directions on restoring the electrical grounding continuity, consult a certified electrician
- **Do not** operate the system if it has a damaged electrical cord or plug, is malfunctioning, or is damaged in any way.
- **To avoid** possible electric shock, extra care should be taken since water may be present near electrical equipment. Unless specifically referred to in these instructions, do not attempt repairs yourself. **Do not** plug the unit in if any electrical surfaces or electrical parts are wet.
- Disconnect power cable from the power outlet by holding the plug. Never pull the cord.
- Ensure that the lamp connector ground wire is connected to the grounding stud on the chamber during service.
- **Do not touch** the lamp or quartz dome by hand. Hold the lamp and dome by the ends with soft dry gloves or cloth.
- **WARNING: NEVER INSTALL UNIT BETWEEN YOUR WELL PUMP & PRESSURE TANK** as that can cause damage to the unit and/or your well pump. Always install after your pump and pressure tank (well or lake water) or after your meter and your main shut off valve (city water).
- **For use on main cold water line only.** Do not pass hot water through the unit.
- **Do not** install in direct sunlight or at a location where the unit may freeze or be subjected to weather elements.
- **Do not** use this unit for any purpose other than its intended use for potable water filtration and disinfection. The use of attachments not recommended, approved or sold by the manufacturer may result in improper performance of the unit or an unsafe condition and void the product warranty.
- **Caution:** The rubber O-rings provide a water tight seal between the filter head and sump of the pre-filter. It is important that they are properly **seated in the grooves** of the sump or a water leak could occur.
- **Do not** over tighten metal fittings into filter INLET or it may crack.
- **Do not** use torch/heat near filter inlet. If necessary, wrap a wet cloth around the pipe and head to absorb heat. All solder joints should be made before joining pipe to the filter head.
- **Do not** use thread sealing compounds. Use thread seal tape for connections into unit.
- **Caution:** **Do not** use petroleum-based lubricants on the unit as that can damage the unit and cause leaks. Use only food grade silicone lubricant available at most retail stores.
- Before any cleaning or maintenance on the system, always unplug the unit from the power source.
- Quartz dome and UV lamp is FRAGILE. Handle with extreme care to prevent breakage

- To ensure continuous protection, **UV LAMP MUST BE REPLACED ANNUALLY**. After 1 year of use, it will no longer provide effective disinfection even though it stays lit.

- **USE ONLY GENUINE RAINFRESH UV LAMPS. Use of non-Rainfresh UV lamps can result in unsafe drinking water and will void your product warranty.** (see page 8 for details)

## (C) WATER QUALITY REQUIREMENTS

The unit should only be operated with water that meets the following minimum criteria:

- **Tannins and Colour:** Water with tannins or colour has low UV transmittance that reduces UV system performance. UV Transmittance of the water should be > 85%. **Caution: The UV system will not work if the water has tannins or colour.** A tannin-removal system should be installed for proper disinfection.
- **Hardness:** Less than 7 GPG (120 mg/L). Hard water causes scale build-up on the quartz dome which will reduce the UV transmittance through the dome and result in reduced performance. The UV system will work with hard water for a short time after which the scale build-up on the quartz dome will cause reduced disinfection performance (unsafe condition). It is therefore recommended that, for hard water, a water softener should be installed prior to the UV system (see Fig 2).
- **Iron & Manganese:** Iron less than 0.3 PPM (mg/L) and Manganese less than 0.05 mg/L is desirable. At higher concentrations, a suitable water conditioner (e.g. an Iron Filter or Greensand filter) should be installed prior to the UV system to prevent iron build-up on the quartz dome that can cause insufficient disinfection.
- **Turbidity/Suspended Solids:** Ideally less than 10 NTU (Nephelometric Turbidity Unit). If the water has high turbidity, a back-washable sediment filter is recommended as a pre-filter.

We highly recommend a water test to confirm that your water quality is suitable for UV disinfection. Rainfresh can test your water quality at no charge. For details, go to [www.rainfresh.ca](http://www.rainfresh.ca) or call Rainfresh.

## (D) INSTALLATION

### INSTALLATION NOTES AND CAUTIONS

- This system must be installed in accordance with local and provincial regulations.
- The MEGA8 System is designed for installation on the cold water line only at the point of entry (POE). For installation in the Province of Quebec, install the unit to serve a max of 2-3 outlets only, but not serving majority of the premises.
- **NOTE: Provide a minimum clearance of 2 feet above the unit for lamp replacement.**
- The system requires a constant power supply of 120V AC.
- It is strongly recommended to have a **dedicated electrical circuit** for the UV system. **A CSA or equivalent certified surge protector must be installed to protect the ballast from electrical surges.** We recommend surge protector rated for a clamping voltage of less than 400 Volts, response time of less than one nanosecond, and energy absorption of at least 600 Joules.
- The MEGA8 system is designed for maximum water flow rate of 8 US GPM (30 liters per minute). If higher flow rates exist occasionally, it is recommended that an 8 US GPM flow restrictor (Rainfresh model FR8K) be installed so that the water does not exceed the max system flow rate.
- The system should be installed indoors in a protected area where the temperature does not fall below 4°C (40°F).
- It is highly recommended to install **bypass piping** with unions and a shut-off valve around the unit. This way you can still have water in case you need to remove the system for service.
- Use only Teflon tape for all connections. Do not use any other sealant on the threads.

## Unpacking the MEGA8 System

Your MEGA8 system includes the following items



**MEGA8 UNIT**  
(Filter cartridges inside housings)



**UV Lamp**  
R830L



**Quartz Dome**  
R830QD



**Ballast**  
R830B2



**Dome O-Ring**  
4032



**Lamp Spring**  
4036



**Ballast Nut & bolts**



**Wrench**  
BH010-5



**Gland Nut**  
4030 with O-ring  
(515) inside

## Install Location

If your water comes from a well or a lake/river etc., the UV should be installed after your pump and pressure tank. To prevent damage to the MEGA8 system, do not install it between well pump and pressure tank. If you have other water filters/conditioner installed, such as softener/iron filter etc., the MEGA8 system should always be installed as the last step of treatment before the water pipes divide into hot and cold (Fig 2).

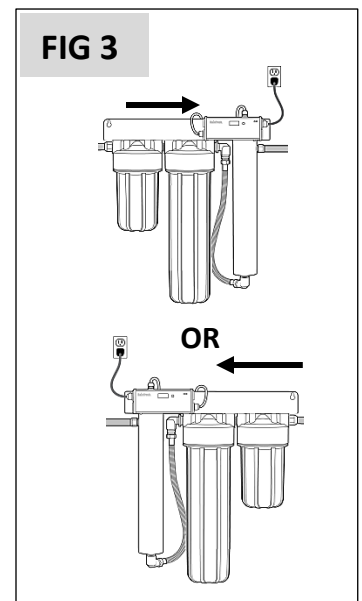
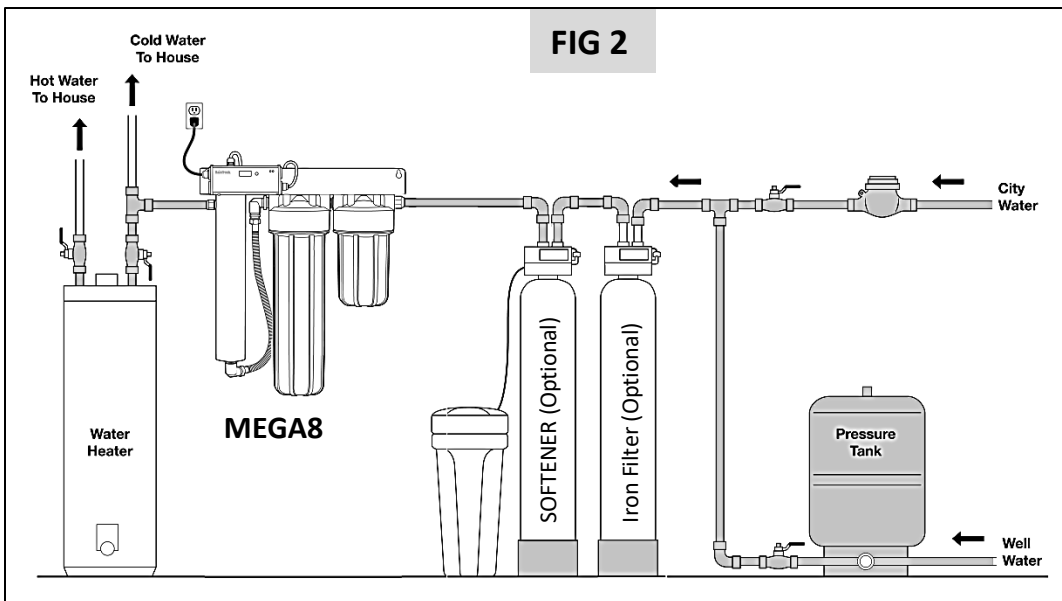

**REVERSIBLE DESIGN:** The MEGA8 system can be installed in two orientations (see Fig 3). Simply position the unit to follow the water flow direction (left to right or right to left) and attach the electronic ballast in the front using the nuts & bolts included with the unit. The ballast is not attached to the unit and is shipped in the inside box. **Note:** It is highly recommended to build a bypass around the system so that you can still have untreated water in the house in case of unit malfunction or if you need to remove the unit for service.

## Fittings Required for Installation (Not Included)

Fittings required for a typical install on 3/4" copper pipe are 1" x 3/4" bushing, 3/4" FNPT female adapter. Depending on the location, you may also need (not necessary) some, 3/4" Tees, 3/4" elbows, 3/4" pipe, 3/4" union couplings and 3/4" ball valves. You may need different fittings if your pipe size or material is different. If you are unsure of what fittings to use, please call Rainfresh. **Note:** UV light can degrade plastics over time. If your water pipe is plastic (such as PEX), it is recommended that you use at least 6 to 12 inches of UV-resistant material (e.g. copper) on the outlet of the unit to prevent damage.

### Installing the MEGA8 unit.

1. The mounting holes on the MEGA8 unit are 16" apart so that you can mount it directly on to wall studs with appropriate screws to carry the weight of the unit. **Warning:** Do not mount the unit directly on drywall without appropriate reinforcement.
2. Install new plumbing using Fig 2 as reference of how the final installation should look.
3. Carefully unpack UV lamp (R830L) and quartz dome (R830QD). **Note:** Hold lamp and dome by the ends with soft, dry gloves or cloth. The gland nut O-ring (515) is in the groove of the gland nut (factory-installed) and the dome O-ring (4032) is in a separate plastic pack.
4. Gently slide the dome O-ring (4032) over the top (open end) of the quartz dome to about 1" from the open end (Fig 4)
5. Gently insert the quartz dome into the gland nut (4030) and gently rotate the dome while pushing in until it goes past the nut O-ring (515) and touches the inside top end of the gland nut. See Fig 5.

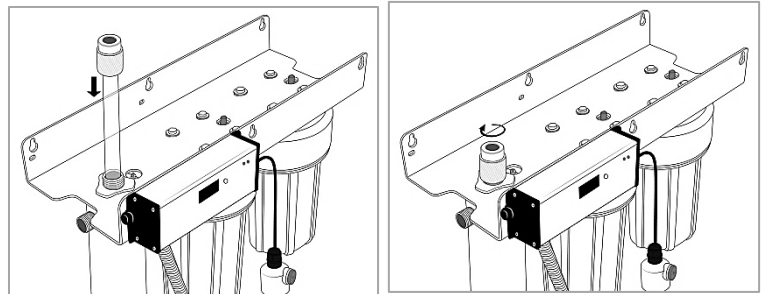
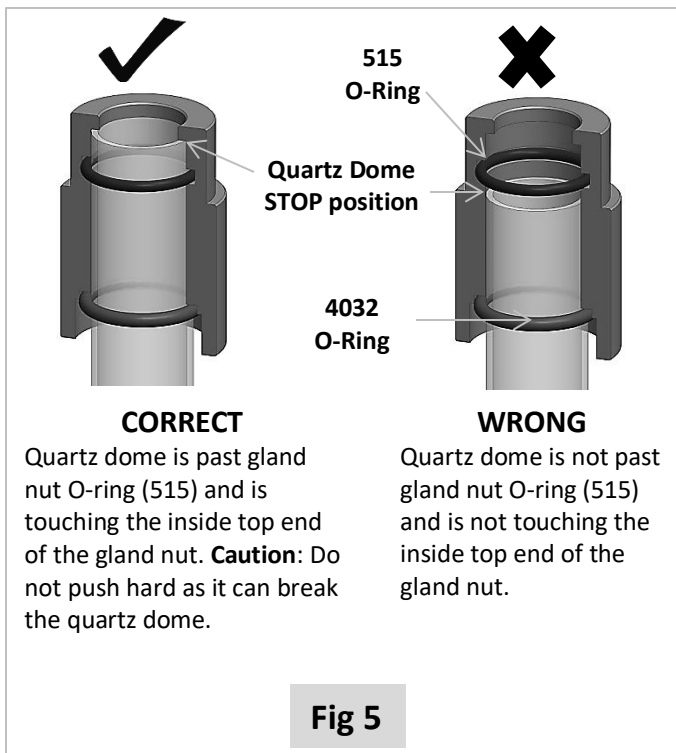
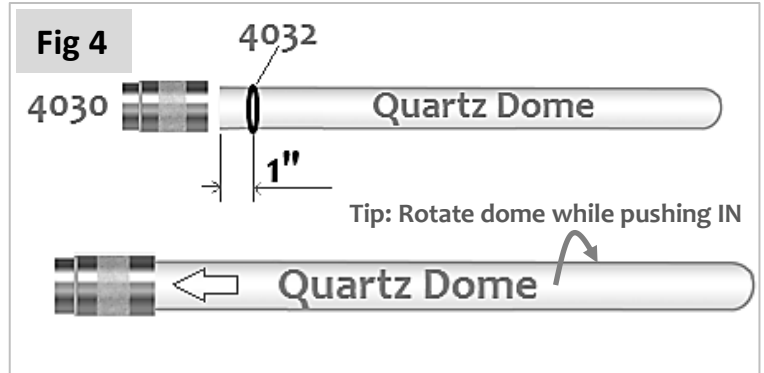

6. Carefully slide the quartz dome with gland nut attached into the opening at the top of the UV chamber and hand-tighten the gland nut into place. **CAUTION:** Do not overtighten the gland nut as it can break the quartz dome. **Note:** Broken quartz domes are not covered under warranty. **Note:** Do not use pipe dope or tape on these top threads before attaching gland nut
7. Slowly open supply-valve and valves before and after UV system. **Check for leaks. Do not proceed to next step until leaks are fixed.**

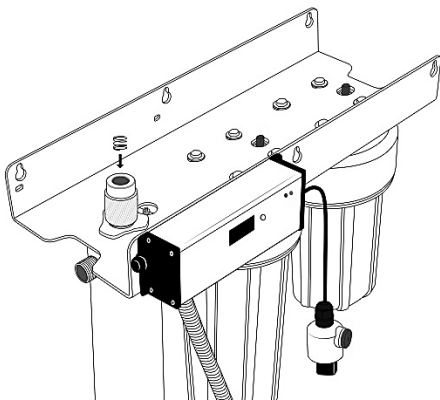

8. From the top of the gland nut, drop the lamp spring (4036) into the quartz dome.

**WARNING:** Installing lamp without the spring in place can cause breakage of quartz dome.

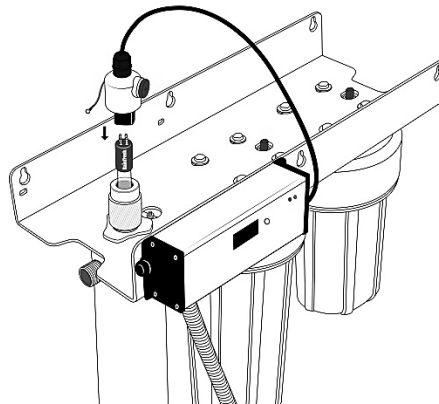

9. Holding the top 4-pin end of the lamp, carefully slide the lamp into the quartz dome and attach the lamp pins to the lamp connector. The lamp connector fits over the pins in only one orientation.

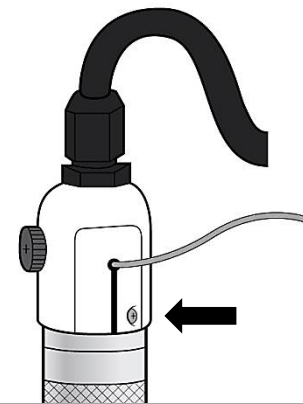

10. Slide the lamp connector cover over the gland nut and tighten the screw on it. Note: Tighten the metal screw, not the red cap.



11. Remove the nut from the ground stud at the top of the unit. Next place the ground wire (green wire with yellow stripes) over the stud and tighten the nut.

12. Connect the power cable to the ballast and then to the AC supply (with surge protector). The green lamp-on LED will light up and the display will show "365". This number indicates the number of days left until lamp life expires and must be replaced. Follow Step (E) before consuming water.

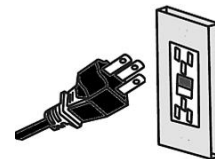

### (E) DISINFECTION PROCEDURE

Before service begins, all household plumbing lines should be disinfected to prevent the possibility of re-contamination after UV disinfection. You should also disinfect your plumbing system if the power goes out for several hours or more or if the unit has been accidentally shut-off for several hours or more. It is advisable to disinfect the plumbing lines at least once a year.

**The following is a general method for disinfection of plumbing lines. If you are uncertain about the efficacy of this procedure you are advised to contact your local health authority responsible for water safety.**

1. Shut off the main water supply valve and de-pressurize the lines by opening a tap.
2. Remove both pre-filters from their respective housings and add about 1-2 cups (250-500ml) of unscented household bleach (5 to 6% sodium hypochlorite) to the first empty filter housing. Re-attach sump to head.
3. Open the supply valve and slowly open a faucet and let the water run until you can smell the chlorine and then shut the faucet off. Repeat the procedure for all hot and cold outlets in the house. Add more bleach as required. Run hot faucets longer to allow the chlorine to come through the hot water tank.
4. Leave the bleach solution in the plumbing system for about 6 to 8 hours preferably overnight. **Warning:** Do not consume water until bleach has been thoroughly flushed (see step 7)
5. Shut-off the supply valve again and open a faucet to depressurize the system. Open the filter housing and re-install the filter cartridge and then re-attach the filter housing. Make sure that the UV system is ON.
6. Take off aerators (if any) on the faucets and open the supply valve slowly.
7. Thoroughly flush all outlets until the chlorine smell is minimal.

**You are ready to use the water now.**

**It is recommended that you have your water tested at a certified laboratory to confirm the safety of your water.**

## (F) BALLAST FEATURES

The micro-processor controlled electronic UV ballast supplied with your Rainfresh UV8B system has both audio and visual alarm indicators to indicate the lamp operation and an integral annual lamp change reminder timer.

**0365** **NORMAL DISPLAY:** Number of days left before lamp expires and must be replaced. Starts at 365 and ends at 0.

**0000** Press button to display the total running days of the unit since installation (maximum 9999 days). Display goes back to default after 10 seconds.

**LF** **“LF” - LAMP FAULT:** If the lamp is disconnected or defective (burned out), the display will show “LF” and the ballast will beep every 2 seconds. If you press the button once, display will show “lamp life remaining” and go back to “LF” after 10 seconds. If you press the button again before 10 seconds, display will show “total running time” and then after 10 seconds go back to “LF”. In the “LF” alarm do not consume water until you replace UV lamp and cleared the alarm.

**A3** **“A3” – LAMP EXPIRY:** If the display shows “A3” alarm with red LED on and ballast beeps every 5 seconds, it indicates that the lamp has expired.

**dELy** You can silence the alarm for 7 days by pressing and holding the button until “dELy” is displayed. You can silence the alarm 3 times after which the alarm will not silence until you replace the UV lamp.

**Warning:** Do not consume water until lamp is replaced.

**rSET** **RESETTING THE LAMP EXPIRY TIMER:** After replacing the UV lamp annually, you must re-set the ballast timer to clear the “A3” alarm. To do this press and hold the button for approx 10 seconds until “rSET” is displayed. Release button and the ballast will emit a long beep to confirm reset. Green LED will come on and red LED will turn OFF. Display will show “365” again.

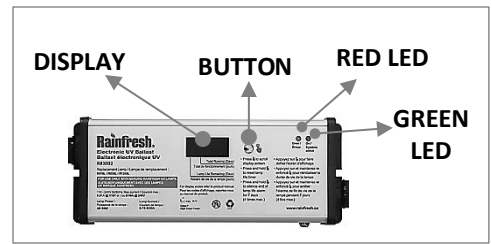

## (G) OPERATION AND MAINTENANCE

Your MEGA8 system is ON continuously during normal use and will continuously supply with safe water.

**Note:** Do not try to shut off the UV during short periods of non-use (such as overnight) as repeated ON/OFF cycles can shorten the UV lamp and ballast life.

To maintain the optimum disinfection performance of the UV system

- UV lamp should be replaced when the display reaches “0”. At this point, the UV lamp continues to light but its ability to disinfect the water drops below safe limits. Therefore the **UV lamp MUST BE REPLACED WHEN THE LAMP REPLACEMENT ALARM “A3” COMES ON.**
- The quartz dome should be cleaned at the time of lamp replacement. If the water quality parameters listed in section ‘C’ are exceeded, you should clean and inspect the quartz dome more frequently and clean as necessary.
- Replace pre-filters every 4-6 months
- Lubricate threads on the sump with silicone lubricant periodically. **Replace sump at least once every 5 years** to prevent costly repairs or water damage. Record date of installation on new sump at the bottom.

ITEM	MODEL	REPLACEMENT FREQUENCY	WHERE TO BUY
Sediment Pre-filter	BC1 or BP5	4-6 months or when pressure across unit drops by 10 psi	Major retailers or home improvement stores or online at <a href="http://www.rainfreshstore.ca">www.rainfreshstore.ca</a>
Carbon Filter	BC202		
UV Lamp	R830L		
Filter O-Rings	BH010-3P	Annually	Order online at <a href="http://www.rainfreshstore.ca">www.rainfreshstore.ca</a>
Quartz Dome	R830QD	Every 3 years	
Dome and Gland Nut O-ring	4032 & 515	Annually	Included with replacement UV lamp or dome
Sumps	BH010-2 & BH020-2	Every 5 years	Order online at <a href="http://www.rainfreshstore.ca">www.rainfreshstore.ca</a>

## CHANGING FILTER CARTRIDGES & REPLACING O-RINGS

1. Shut off the inlet valve and open a faucet close by until pressure in the unit is relieved. Alternatively you can press the red vent button on top of the unit until pressure is released.
2. Place an empty bucket under the sump to catch any water spilling out of the housings
3. Using the supplied wrench, unscrew the sump. Discard old cartridge and rinse sump.
4. Remove O-rings (BH010-3P) and replace if they have been in use for a year. Otherwise wipe them with a soft cloth or paper towel and clean the groove on which the O-rings are seated.
5. Apply food-grade silicone lube on the O-rings and place back into sump.
6. Clean inside of the head as well to make sure the sealing surface is free of debris and stains.
7. Insert new cartridge into the sump and screw sump back on to filter. Hand-tighten only. **CAUTION: DO NOT USE WRENCH TO TIGHTEN SUMP.** Slowly open the water and flush for a few minutes before use.

## REPLACING THE UV LAMP AND CLEANING QUARTZ DOME:

### USE ONLY **GENUINE** RAINFRESH UV LAMPS

Use only GENUINE RAINFRESH UV Lamps with your UV system. Rainfresh UV lamps are designed with extensive product research and engineering to provide reliable and consistent UV output and performance that ensures the safety of your drinking water. Using non-Rainfresh UV lamps can not only compromise the system performance but also voids your product warranty, electrical and CSA certification, and may result in any one or more of the following issues:

- Unsafe drinking water
- Ballast failure
- Electrical fire

**Use of non-Rainfresh lamps will void all warranty & product certification**

Genuine Rainfresh UV lamps can be identified as follows:



1. Turn off supply valve before the unit and then unplug unit from electrical outlet. Open a faucet to depressurize the MEGA8 system and turn off the valve at the outlet port to isolate it. **WARNING: DO NOT LOOK DIRECTLY AT UV LAMP WHEN LAMP IS ON.** UV light can cause serious burns to eyes & skin.
2. **CAUTION:** The lamp end can be very hot. Wait several minutes for the lamp to cool down.
3. Unscrew the ground nut and remove the ground wire (green wire with yellow stripes).
4. Loosen the screw on the lamp connector cover and remove cover from the gland nut.
5. Carefully slide UV lamp slightly out of chamber and hold the lamp end with one hand. Gently pull off the connector with your other hand to disconnect the lamp completely. Slowly remove lamp from the disinfection chamber completely.
6. Remove the quartz dome by loosening the gland nut and carefully extracting from the unit. Remove dome absolutely vertically from its position until the other end comes out. **CAUTION:** If you bend the dome mid-way, it can break easily and pieces of quartz can fall into the UV chamber. Do not lose the spring.
7. Remove & discard used dome "O" ring. Clean dome gently with a vinegar solution or a household scale-removal product. **Do not use abrasive pads.** A soft cloth or paper towel is recommended.
8. Using a small pointed tool carefully take the "O" ring out of the gland nut. Take care not to scratch the gland nut.
9. A dome "O" ring (thicker) and gland nut "O" ring (thinner) are included with the lamp. Slide gland nut "O" ring into the internal groove of the gland nut.
10. Follow instructions 6 to 11 in previous section "Installing the MEGA8 Unit". Plug in the ballast
11. Press and hold the button for approx 10 seconds until "rSET" is displayed. Release button and the ballast will emit a long beep to confirm reset. Green LED will come on and red LED will turn OFF. Display will show "365" again.

## WINTERIZING YOUR SYSTEM:

To winterize the system, unplug the unit first. Drain the pre-filters by removing the sumps and dumping the water. Let the filter cartridges dry out and then reinstall in the housing. To drain the UV, undo the SS flex connector (part # 4156) from the bottom until the UV drains completely. Re-attach the flex connector. Leave the UV lamp and dome inside. When turning unit back on, plug the ballast first and slowly allow water into the unit. Wait for about 10 minutes and flush water through for a few minutes before consuming water.

## (H) TROUBLESHOOTING

PROBLEM	PROBABLE CAUSE	SOLUTION
Leak at gland nut	Gland nut is loose or O-ring defective	Hand-tighten gland nut & replace O-ring(s)
Condensation outside the UV chamber	High humidity in the environment	This is normal if humid conditions exist. Install dehumidifier to protect ballast. Protect flooring below UV
Hot water coming out of taps/faucets	Water inside UV unit becomes hot after long periods of non-use. You may have oversized the unit for the home	To prevent scalding, before using water after periods of non-use such as overnight, flush water for about 2 minutes. Install a temperature controlled purge valve on the UV outlet
UV lamp ends seem burnt after some time	This is normal	As long as the UV lamp lights, a little burn mark at the ends is normal and there is no need to replace the UV lamp
Sump is difficult to remove	<ul style="list-style-type: none"><li>• Unit may still be under pressure</li><li>• Head seal may be stuck to sump</li></ul>	<ul style="list-style-type: none"><li>• Close supply valve and open a faucet to release pressure</li><li>• To break the seal, use a pipe on the wrench handle as extra leverage to open the housing. <b>Never use wrench to tighten the sumps.</b> Always lubricate the O-rings with food grade silicone and replace annually</li></ul>
Leak at pressure relief valve	Debris under vent seal	Replace vent O-ring

## (I) TECHNICAL SPECIFICATIONS

PRODUCT SPECIFICATION	MEGA8
Suitable for Homes with	Up to 3.5 bathrooms
Max Rated Water Flow Rate	8 US GPM (30 LPM)
UV Dose at Max Rated Flow	> 40 mJ/cm <sup>2</sup> @ 85% UVT
AC Supply Voltage	120VAC ; 50/60 Hz, 0.8A max
Power Consumption	48 Watt max
Disinfection Chamber Material	Stainless Steel 304
Operating Pressure psi (kPa)	10 – 90 psi (68.9 – 620 kPa)
Water Temperature Range	4 – 37°C (40 – 99F)
UV Lamp Model	R830L
Lamp Service Life	9,000 Hours (Approx. 1 year of use)
Quartz Dome Model / Service Life	R830QD / 3 years
Sediment Pre-filter model/Service Life	BC1 or BP5 / 4-6 months
Carbon Pre-filter model/Service Life	BC202 / 4-6 months
Inlet/Outlet Port Size	1" FNPT / ¾" Male NPT

## (J) PARTS LIST

#	PART NUMBER	DESCRIPTION	QTY
1	515	Gland Nut O-Ring (Thinner – installed inside 4030 nut)	1
2	R830L	UV Lamp	1
3	R830B2	Ballast, power cord & lamp connector assembly	1
4	R830QD	Quartz Dome	1
5	4154	SS UV Chamber for MEGA8	1
6	4030	Gland Nut	1
7	4032	Dome O-Ring (Thicker)	1
8	4036	Lamp Spring	1
9	BC1 or BP5	5 micron sediment pre-filter cartridge	1
10	BC202	Activated carbon block pre-filter	1
11	BH010-1	Pre-filter head	2
12a	BH010-2	Sump for sediment pre-filter	1
12b	BH020-2	Sump for carbon pre-filter	1
13	BH010-3	Sump O-rings for both pre-filters. Sold as 2-pk (BH010-3P)	2
14	BH010-4	Pressure vent button & O-ring	2
15	BH010-5	Wrench to open pre-filter housings	1
16	6010	1" Nipple	1
17	6007	1"x3/4" reducer bushing	1
18	1014-0	3/4" HEX Nipple	1
19	6012	3/4" street elbow	2
20	3412	BH mounting screws	8
	3413	BH mounting washer	8
21	4156	3/4" x 3/4" Flex Tube, 24"	1
22	4150TN	Chamber Mounting SS Nut	1
23	4155	Mega bracket	1

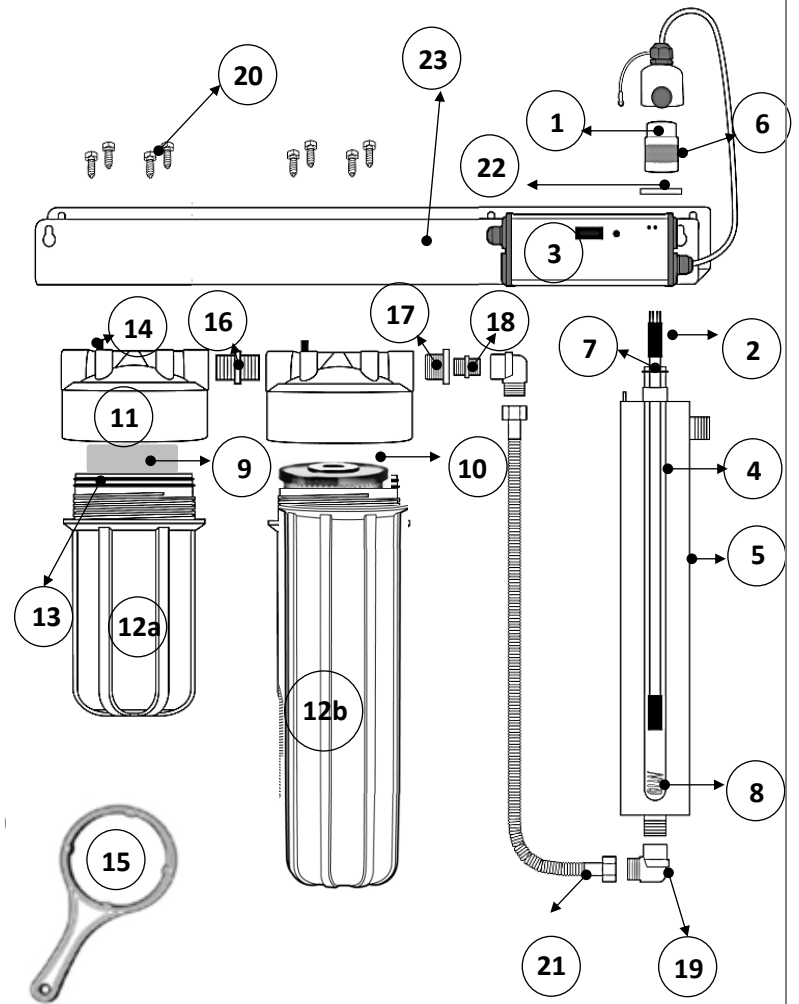

## (K) LIMITED WARRANTY

The MEGA8 System stainless steel housing is warranted to the original Consumer purchaser for a period of seven (7) years, from the date of purchase, against defects in materials or workmanship. Miscellaneous hardware, seals and electrical system, pre-filter housings and bracket are warranted to the original Consumer purchaser for a period of one (1) year, from the date of purchase, against defects in material or workmanship. The Ultraviolet lamp is warranted for a period of thirty (30) days from the date of purchase against defects in materials and workmanship. The company's obligation under this warranty shall consist of repair or replacement, at its option, of any part found by company inspection to be defective, provided that the product has not been misused, abuse, altered or damaged by Consumer with respect to the original installation, as determined by the company. This warranty will not apply if water passing through the MEGA8 System has a) Turbidity > 10 NTU. b) Hydrogen Sulphide concentrations greater than 0.05 PPM (0.05 mg/l). c) Iron concentration greater than 0.3 ppm (0.3 mg/l) or Manganese greater than 0.05 ppm (0.05 mg/l). d) Hardness concentrations greater than 7 GPG (119 PPM). e) Tannins or colour. This limited Warranty applies only to a unit when returned to the Warrantor at the owner's expense and in accordance with shipping instructions received from the Warrantor. This warranty does NOT cover, and is intended to exclude, any liability on the part of Envirogard for any incidental damages, consequential damages, labour charges or any other costs incurred in connection with the purchase, installation, use, maintenance or repair or the water filter whether under this warranty or any other warranty implied by law. Some provinces/states do not allow the exclusion of incidental or consequential damages, so the above limitation or exclusion may not apply to you. This warranty gives you specific legal rights and you may also have other rights, which vary from province/state to province/state. This warranty applies only to water filter/systems purchased in Canada or the U.S.A.



### ENVIROGARD PRODUCTS LIMITED

446 MAJOR MACKENZIE DRIVE EAST, RICHMOND HILL, ON L4C 1J2, CANADA

TEL : (905) 884 9388 HELPLINE: 1800 667 8072 WEB: www.rainfresh.ca

© COPYRIGHT • ENVIROGARD PRODUCTS LIMITED 2026 • ALL RIGHTS RESERVED