

# ESS1

## Stainless Steel Filter Housing



Rainfresh ESS1 filter housing is constructed of durable stainless steel and meets general purpose industrial and commercial filtration needs.

The ESS1 filter housing accommodates a single cartridge of 10" nominal length and 2.5" diameter, and handles liquids at pressures and temperatures of up to 150 psi at 176°F.

### Design Features

- Heavy-duty, rugged SS304 construction
- Positive cartridge seal
- Clamp with tool for quick and easy opening
- Housing uses 9¾", 9 7/8" or 10" cartridges
- Heavy duty cast head

### Applications

ESS1 filter housing can be used for a variety of industrial & commercial applications, such as:

- Glycol filtration in commercial buildings
- Hot water filtration in industries and commercial buildings
- Sediment filtration in high-pressure applications

### BENEFITS

- Heavy Duty Design
- Rugged, Long-lasting
- Stainless Steel Construction
- Easy Cartridge Change-out

## Specifications

Table 'A' lists general specifications for ESS1 model housing. Note that maximum operating temperature and pressure is for housing only. Actual system operating conditions depend on the filter cartridge used.

Model	Inlet / Outlet	Max Pressure*	Max Flow Rate	Water Temp Range**	No. of Cart. (Cart Dimension)	Shipping Wt
ESS1	¾" FNPT	150 psi (10 bar)	7 GPM (26.5 LPM) @ < 5psi ΔP	4°C to 121°C (39°F - 250°F)	1 cart, 10"Lx2.5"Ø	6 lbs 2.7 Kg

Cartridge not included.

\* -If water pressure exceeds the rated pressure, a pressure regulator must be installed before the filter housing.

\*\* - Temperature rating for housing only. For temperatures > 38°C, hot water cartridges must be used

**Table A**

When sizing filtration system, amount of contaminant to be removed should be considered in addition to flow rate and desired pressure drop. Systems sized on low initial pressure drop have enhanced cartridge life.

## Installation notes:

Unit Width (Inch)	Unit Height (Inch)	Unit Depth (Inch)	Cartridge Type
4"	14"	4"	Double open end

- Caution: Do not use for air or compressed gas filtration
- Mounting bracket and sump-opening tool included

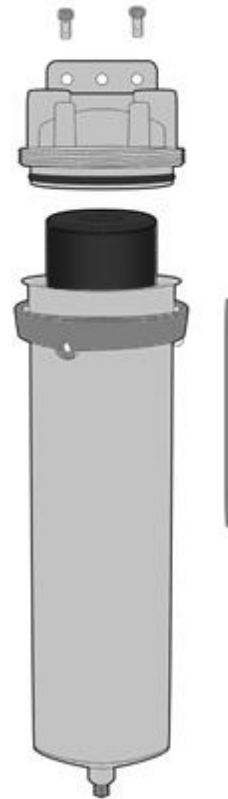
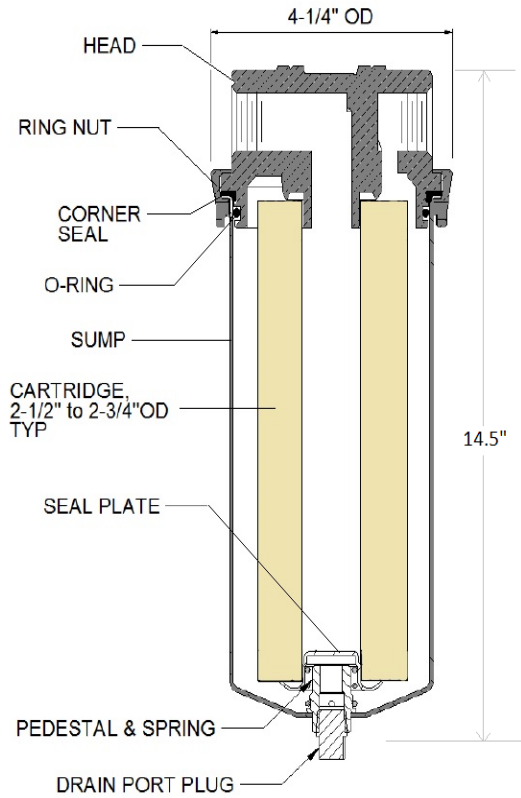

## Replacement Cartridges:

Accommodates 10" L x 2.5" dia (nominal dimensions), double open end, standard or hot water cartridges.  
Call Rainfresh for model number choices.

1 year limited warranty



## Envirogard Products Limited

446 Major Mackenzie Drive East,  
Richmond Hill, ON L4C 1J2, CANADA

**Toll Free:** 1 800 667 8072 ; **Tel:** (905) 884 9388

**Fax:** (905) 884 3532 ; **E-Mail :** info@rainfresh.ca

**Web:** www.rainfresh.ca