



## Water Softener • Model 30C / 40C Installation and Operation Instructions

(Please read carefully before proceeding and retain for future reference)

Thank you for purchasing a Rainfresh Product. We are committed to ensuring that you are totally satisfied.

For any questions, please contact customer service:

**Customer Service** • 001 (905) 884 9388

**Canada Toll Free** • 1800 667 8072 (Mon to Fri 8:30 AM to 5:00 PM EST)

**E-Mail:** customersupport@rainfresh.ca • **Web:** www.rainfresh.ca

### CONTENTS

<b>A. Technical Specifications and Performance Data</b>	<b>2</b>
<b>B. How Your Water Softener Works</b>	<b>2</b>
<b>C. Safety Precautions and Cautions</b>	<b>3</b>
<b>D. Installation</b>	<b>3</b>
1. Electrical Requirements	3
2. Packing List	3
3. Plumbing in the Softener	4
<b>E. Start-up and Programming</b>	<b>8</b>
1. Language Selection	8
2. Program Household Settings	9
3. Disinfecting the Softener	11
4. Manual Regeneration	11
5. Advanced Programming	12
<b>F. Optional Programming</b>	<b>13</b>
<b>G. Other Features</b>	<b>14</b>
<b>H. Maintenance</b>	<b>14</b>
• Service Schedule	15
<b>I. Troubleshooting</b>	<b>18</b>
<b>J. Warranty</b>	<b>20</b>

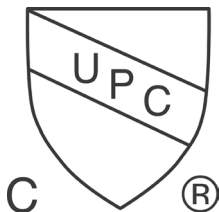

Certified by IAPMO R&T against CSA B483.1 and NSF/ ANSI 44.

## A. TECHNICAL SPECIFICATIONS AND PERFORMANCE DATA

MODEL NUMBER	30C	40C
Qty High Capacity resin	0.88 ft <sup>3</sup>	1.06 ft <sup>3</sup>
Resin Type	High capacity cation softening resin	
Rated Service Flow (GPM)	10.5	11.9
Pressure Drop at Rated Service Flow (psi)	12.0	15.0
Rated Softening Capacity (Grains)	10,263 @ 2.64 lbs	14,456 @ 3.18 lbs
Efficiency (grains/lb salt)	3,887	4,543
Max Flow Rate to Drain (GPM)	2.4	2.4
Working Pressure	25 – 100 psi* (172 – 689 kPa)*	
Operating Temperature	39 – 100°F (4 – 38°C)	
Voltage	110 V AC	

\* **Note:** Install pressure regulator and water hammer arrestor if pressure exceeds rated pressure at any time.

The manufacturer reserves the right to make product improvements which may deviate from the specifications and descriptions stated herein, without obligation to change previously manufactured products or to note the change.

These softeners conform to NSF/ANSI 44 for the specific performance claims as verified and substantiated by test data. These models are efficiency rated. The efficiency rating is valid only at the stated salt dose and maximum service flow rate. They have a demand initiated regeneration (D.I.R.) feature that complies with specific performance specifications in-tended to minimize the amount of regenerant brine and water used in their operation. These softeners have a rated softener efficiency of not less than 3350 grains of total hardness exchange per pound of salt (based on sodium chloride) and shall not deliver more salt than their listed ratings. The rated salt efficiency is measured by laboratory tests described in NSF/ANSI Standard 44. These tests represent the maximum possible efficiency that the systems can achieve. Operational efficiency is the actual efficiency after the system has been installed. It is typically less than the efficiency due to individual application factors including water hardness, water usage, and other contaminants that reduce the softener's capacity.

### Feed Water Quality:

Iron < 0.5 PPM

Manganese < 0.05 PPM

Turbidity < 1 NTU

Free Chlorine < 0.5 PPM

Hydrogen Sulphide – Nil

Organics – Nil.

If feed water quality exceeds above limits, please call Rainfresh for advice on additional treatment that may be necessary.

**Salt Use:** This water softener requires the addition of softener salt (not included). Without salt, the unit will not function. Salt does not go into your water. Salt is only used to recharge the softener resin with sodium after the capacity has been exhausted. Following this saltrecharge, the softener undergoes a rinse cycle during which any left-over salt is discharged to drain. However, soft water does have higher levels of sodium. You can also use potassium chloride salt.

**How often to add salt:** Open the salt lid and check the salt level frequently. If the softener uses up all the salt before you refill it, you will get hard water. Until you have established a refilling routine, check the salt every two or three weeks. Always add if less than ¼ full. The salt level should always be above the water level. **NOTE:** In humid areas, it is recommended that you keep the salt storage level lower, and to refill more often to avoid salt "bridging" (see page 14).

**Which type of salt to use:** Use only clean salt specifically labelled for water softener use, such as pellet or nugget. Softener salt is available at Canadian Tire stores. **Note:** Never use rock salt, granulated or salt for ice melting. These salts contain insoluble silt and sand which build up in the brine tank and cause problems with the system's operation.

## B. HOW YOUR WATER CONDITIONER WORKS

Your Rainfresh Softener removes hardness using a process called Ion Exchange. In this process, when hard water flows through the unit, hardness-causing minerals such as Calcium and Magnesium, are trapped by the media (called Resin) and an equivalent amount of sodium ions are released into the water. When the capacity of the resin to trap hardness minerals is exhausted, the unit is re-charged by softener salt in an **automatic process** called **Regeneration**. During regeneration, the unit first backwashes to remove any sediment, rust or other particulates, that may have accumulated in the unit. This is followed by introduction of a saturated salt solution (brine) that bumps off the trapped hardness to drain and recharges the resin with sodium. It then goes through a final rinse and refills the salt tank with water for the next regeneration.

Once you program the unit at the time of installation, the regeneration process happens automatically. All you need to do is to ensure that there is always enough salt in the salt tank. The unit automatically calculates when to regenerate based on your water hardness and use.

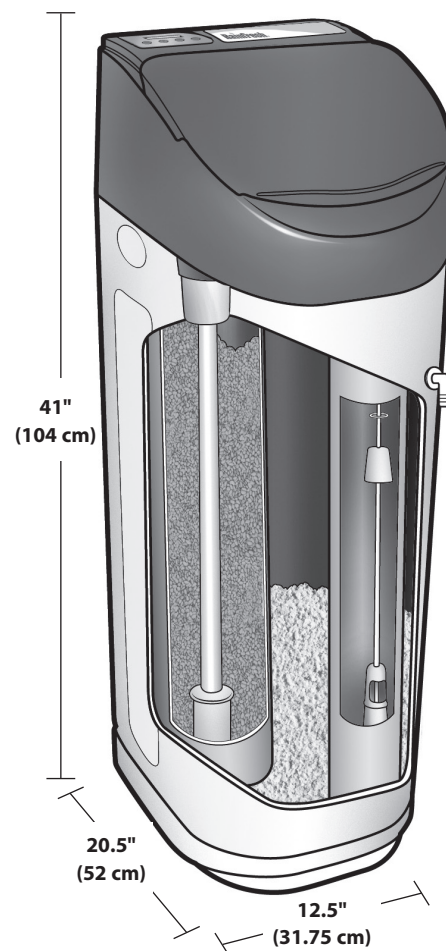

## C. SAFETY PRECAUTIONS AND CAUTIONS BEFORE INSTALLATION

- Installation shall comply with all applicable province and local regulations.
- Handle your water softener carefully. Do not lie on side, turn upside down, drop or drag.
- This unit requires softener salt (sodium chloride) to regenerate. Softener salt is available at Canadian Tire stores. Persons on sodium restricted diets should consider the added sodium as part of their overall intake. Potassium chloride can be used as an alternate in such situations.
- Install a pressure regulator and water hammer arrestor if pressure exceeds maximum rating at any time. **Note:** If daytime pressure is over 80 psi, night time pressure may exceed maximum pressure rating.
- Do not install on water that is microbiologically unsafe without adequate disinfection before or after the unit. For effective disinfection install a UV disinfection system available at Canadian Tire stores.
- For use with residential cold water only.
- **Only use thread seal tape** (PTFE tape) for fitting connections into unit. **DO NOT USE pipe dope or chemical sealants.**
- If water pipes are used to ground electrical system, install jumper wire (#4 gauge solid copper wire) across the unit to maintain proper grounding of your electrical system.
- **Protect your unit from freezing** - drain the unit if freezing temperatures exist.
- **NOTE: IF SOLDER TYPE FITTINGS ARE USED DO NOT USE torch near inlet/outlet connections.** All solder joints should be made before joining pipe to filter head. Use only lead-free solder and flux.
- **DO NOT over-tighten** metal fittings on to unit connections.
- Place the unit on a flat level surface. Do not place shims under the unit to level it. The weight of the unit full of water and salt can cause the cabinet to crack at the shim.
- The unit should only be moved by 2 or more people due to heavy weight. Failure to do so can result in injury.
- The unit must be installed in an area where there is reasonable access to the salt tank for regular salt filling.
- Only use approved food grade silicone lubricant. **DO NOT** use vaseline or other petroleum based products.
- Do not install in multi-storey buildings over 4 storeys.
- Avoid installing in direct sunlight. Excessive sun heat may cause distortion or other damage to non-metallic parts.

## D. INSTALLATION

### Electrical Requirements:

- The automatic control valve requires a constant power supply: 110 V AC. We recommend a GFI (ground fault interrupter) outlet within 5' (1.5 m) of the softener. Extension cords are not recommended.
- If water pipes are used to ground electrical system, you will need to install a jumper wire across the softener unit.

### PACKING LIST

Softener with built-in salt tank and bypass valve



Inlet / Outlet elbow fittings (2) - 3/4" Male NPT (6208)

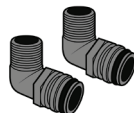

Hex key (for ease of opening & closing bypass valve)



Drain hose (15 ft) with hose clamp



AC power adapter (6203)

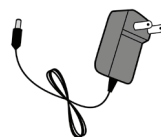

Lubricant pack



Unpack the unit and **discard the plastic air pack** inside the unit. Place the unit at the location where you intend to install it.

- Stand back and look at the softener to make sure it is standing straight up and not tilted to one side. Make sure your chosen location will be fairly level, dry, and protected from possible freezing conditions. The softener can sit directly on the floor and will not corrode. **DO NOT** set the softener onto makeshift platforms as this can damage the salt tank, or may cause it to topple.
- The system has 3 connections - an inlet, an outlet, and a drain line connection (the drain line connection is underneath the cabinet top). If you are looking at the back of the unit (**FIG. 1A**), the inlet is on the left side. **Warning:** Make sure that you have correctly identified the inlet of the system. **REVERSING THE CONNECTIONS WILL RESULT IN RESIN BEADS BEING THROWN INTO YOUR HOME'S PLUMBING SYSTEM CAUSING DAMAGE TO IT AS WELL AS THE SOFTENER.**
- Remove the red locking clip by hand on the inlet side (**FIG. 1A**). Using the silicone lubricant included, lubricate the O-ring on the fitting and insert it firmly into the INLET side (**FIG. 1B**). Reinstall red locking clip. Repeat this procedure with the other fitting into the OUTLET side. **Note: Never remove any of the red clips on the sides of the control head or flooding can occur.**
- The following pipe can be used for installing your new system - Copper, CPVC, and PEX are the most popular.

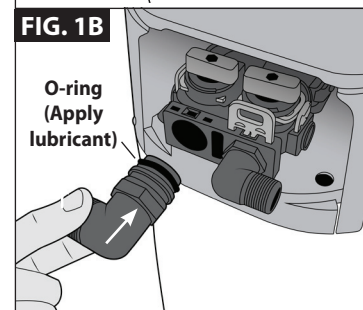
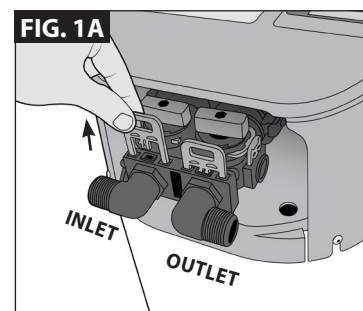

## Installation Location

Installation location for city (municipally treated) water.

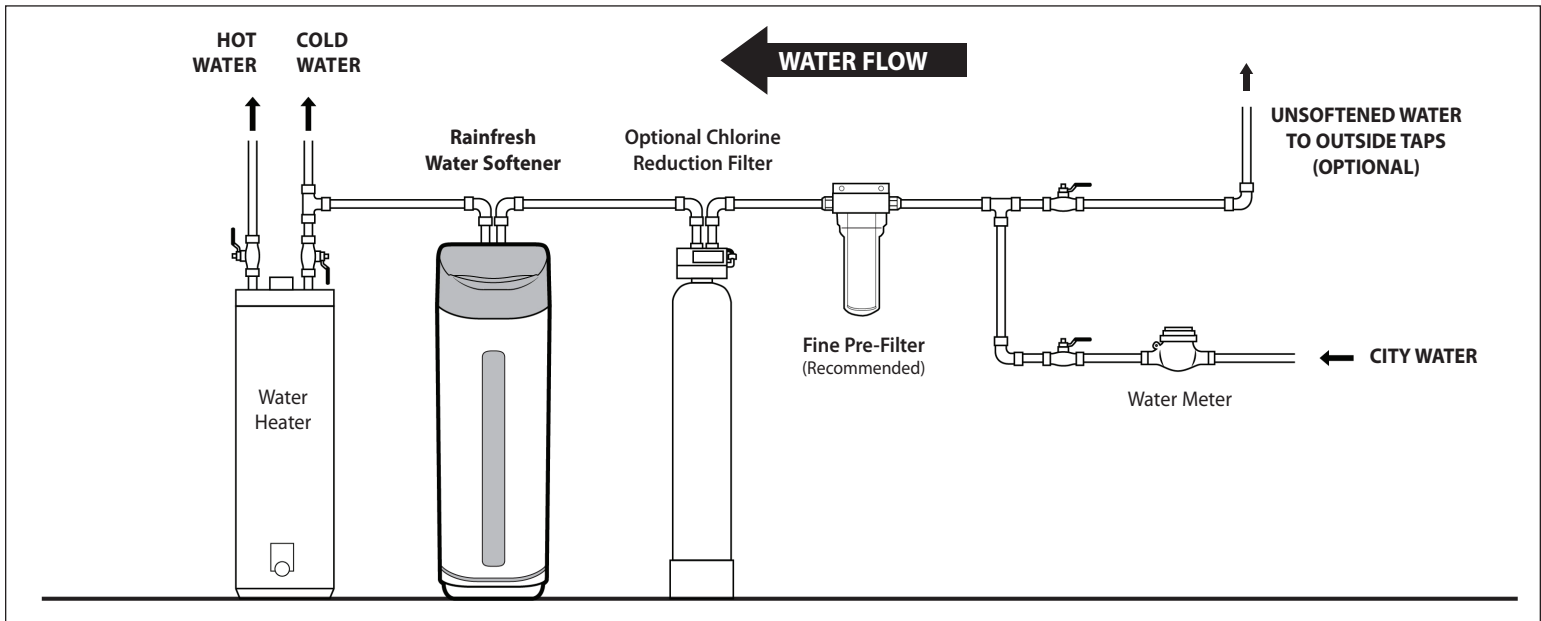

Installation location for well water.

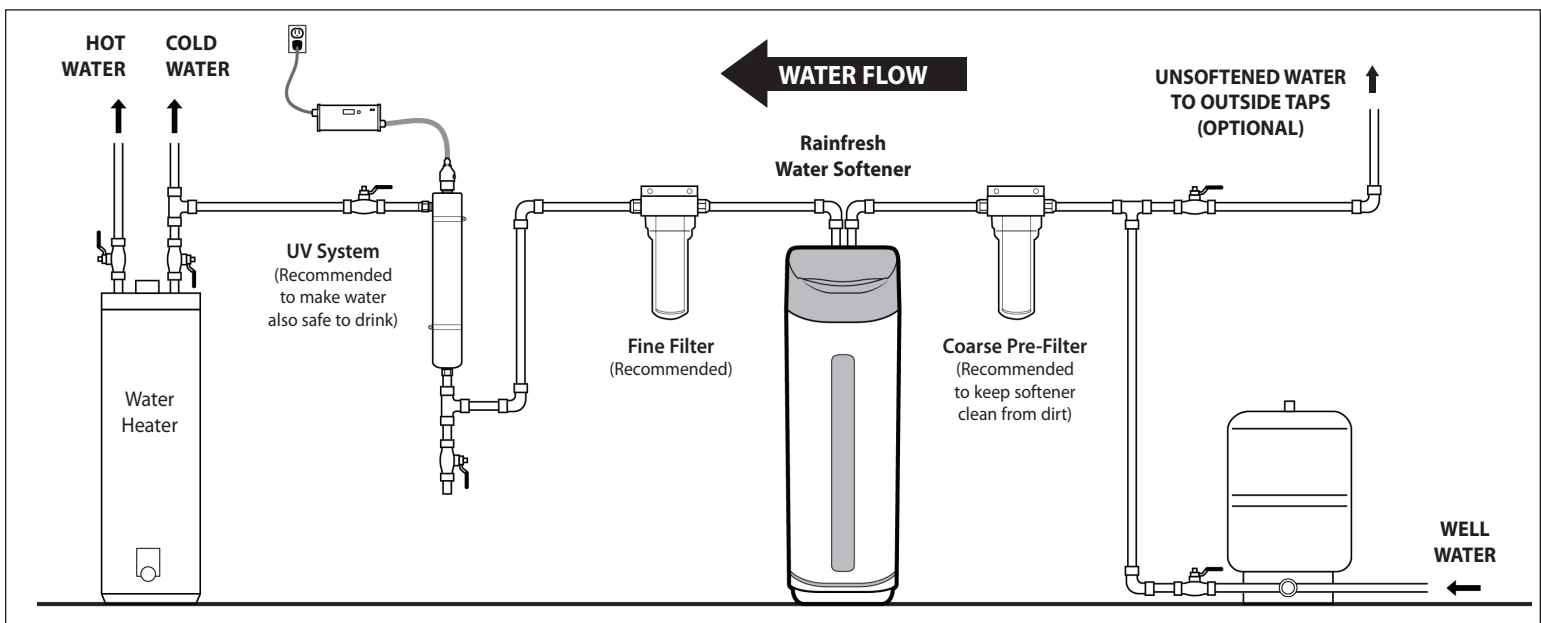

## Plumbing in your softener

- If your hot water tank is electric, turn off the power to it to avoid damage to the element in the tank.
- If you have a private well, turn the power off to the pump then shut off the main water shut off valve. If you have municipal water, simply shut off the main valve. Go to a faucet, (preferably on the lowest floor of the house) turn on the cold water until all pressure is relieved and the flow of water stops.
- Position the softener in the desired location. **Make sure that the bypass valve is in bypass position as shown in FIG. 2B (use the hex key to turn the handles).**
- **Note:** To change the connection fitting, simply remove the locking clips by hand (FIG. 3A) and pull the fitting out (FIG. 3B). Lubricate the O-ring on the new fitting and insert fitting firmly into the unit. Reinstall locking clip.  
**Note: Never remove any of the red clips on the sides of the control head.**

**FIG. 2A****SERVICE POSITION**

Handles pointing to unit

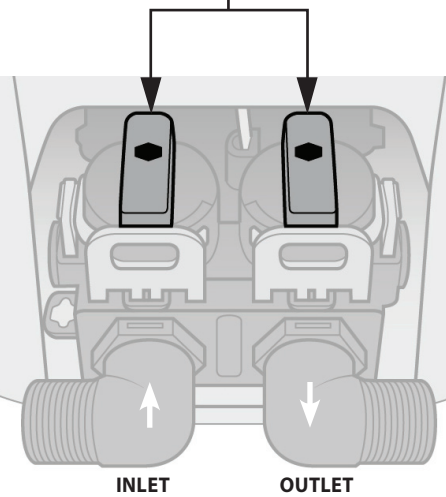
**FIG. 2B****BYPASS POSITION**

Handles pointing sideways

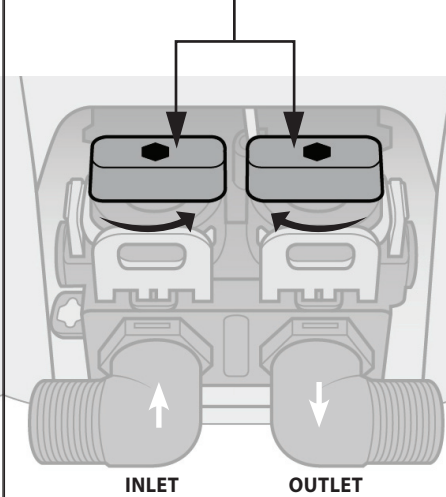
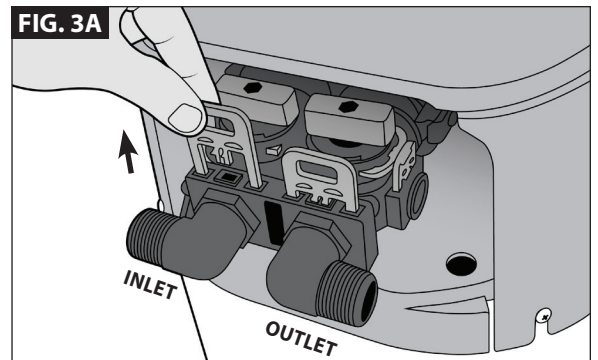
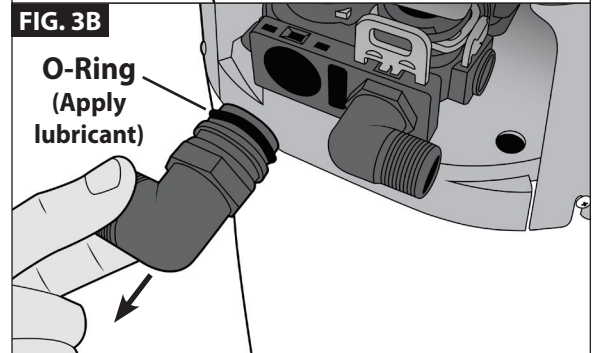
**FIG. 3A****FIG. 3B**

- Plumb in the softener using appropriate fittings. The 90° MNPT elbow fittings can be rotated at any angle to suit your installation (FIG. 4).
- Unscrew the cabinet top using a screwdriver (FIG. 5) and place the top aside, making sure that the electronic cable underneath does not detach from the circuit board (FIG. 6A).
- Attach the drain hose (15 ft included) to the drain fitting (FIG. 6A) and secure it with a hose clamp (FIG. 6B) (included).
- Run the drain line to a nearby laundry tub, standing pipe or floor drain (FIG. 7) and cut off excess tubing.
- Reinstall cabinet top and be careful not to pinch drain tube or electronic cable underneath.

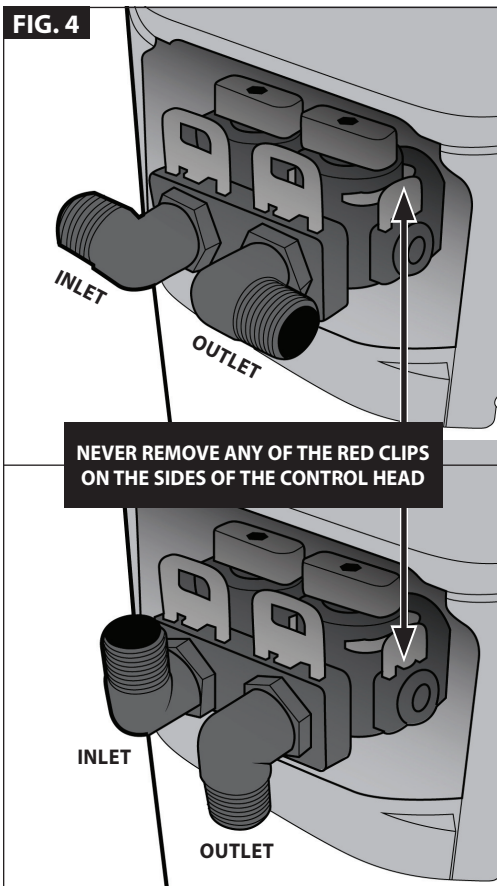
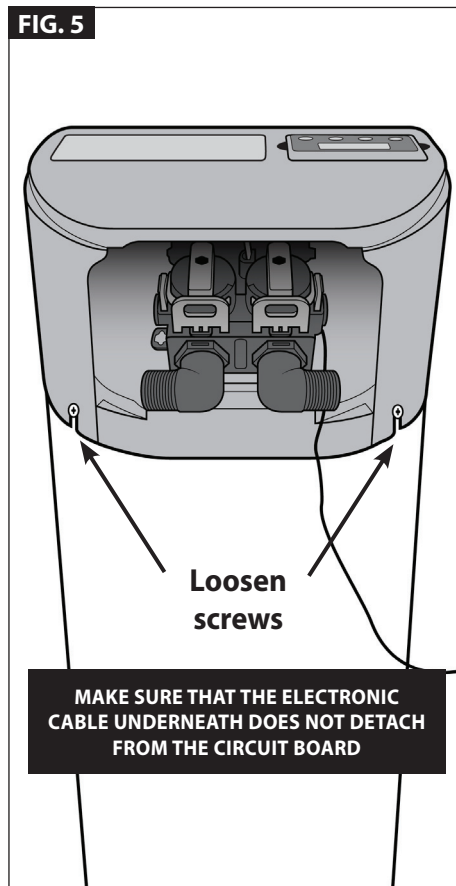
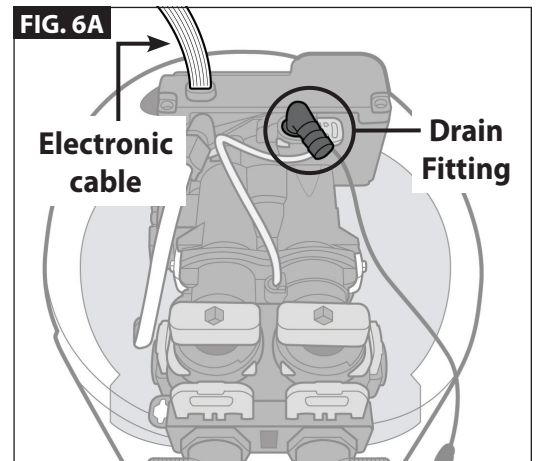
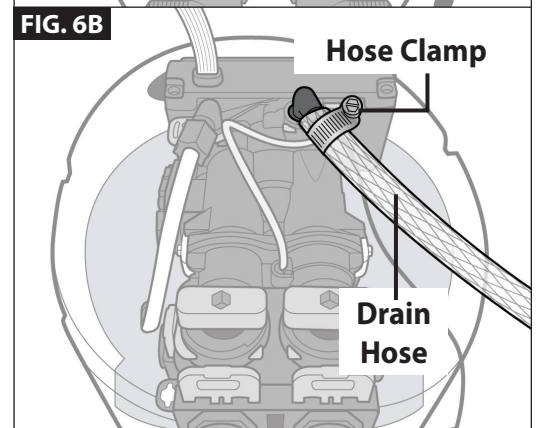
**FIG. 4****FIG. 5****FIG. 6A****FIG. 6B**

**NOTE ABOUT DRAIN LINE :**

You can run the drain hose from the unit to the ceiling joists (max. 8' / 2.4 m ceiling) and run it to the nearest laundry tub or drain pipe. This can be run up overhead or down along the floor. Use band clamps to hold the drain tubing in place. If running drain line more than 15' (4.6 m) from the softener (max. 25' / 7.6 m), increasing the line size to 3/4" will be required. Please follow your local plumbing and other applicable codes for where to run softener discharge water.

**NEVER MAKE A DIRECT CONNECTION INTO A WASTE WATER DRAIN. A PHYSICAL AIR GAP OF AT LEAST 1.5" SHOULD BE USED TO AVOID BACTERIA AND WASTEWATER TRAVELING BACK THROUGH THE DRAIN LINE INTO THE SOFTENER (FIG. 7).**

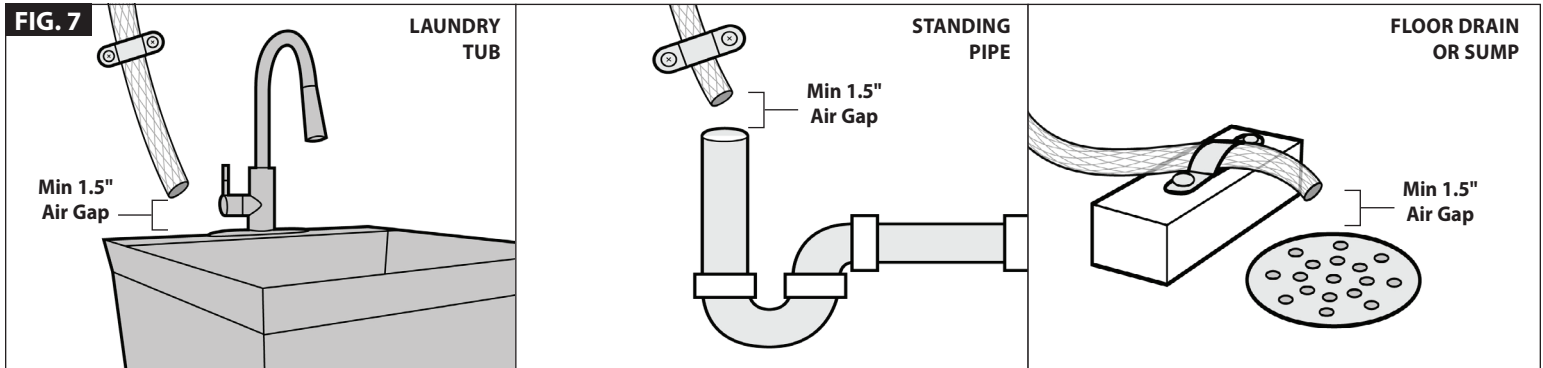

**Attaching the overflow tubing**

- The overflow fitting is pre-attached to the cabinet (FIG. 8).
- Attach the rest of the drain tubing to the overflow fitting and run to the floor drain with an appropriate air gap, as shown in FIG. 7. If you do not have any more drain tubing left, you will need to purchase extra tubing at your local plumbing retailer. A hose clamp is also recommended to hold the tubing on the fitting.
- The salt tank is pre-connected to the control head. Slide the cabinet lid and add about 5 gallons of water in the salt tank (FIG. 9). This is not a critical level but just helps with the process for the first regeneration. Then add 2 bags (20 Kg bags) of salt to start with. **DO NOT OVERFLOW WITH SALT** to prevent salt bridging (refer to FIG. 15).
- Turn main house shut-off valve on slightly and watch for leaks. Ensure a faucet is on somewhere and that it's screen is removed to avoid clogging from loosened scale in the pipes. If you have no leaks, proceed to the next step.

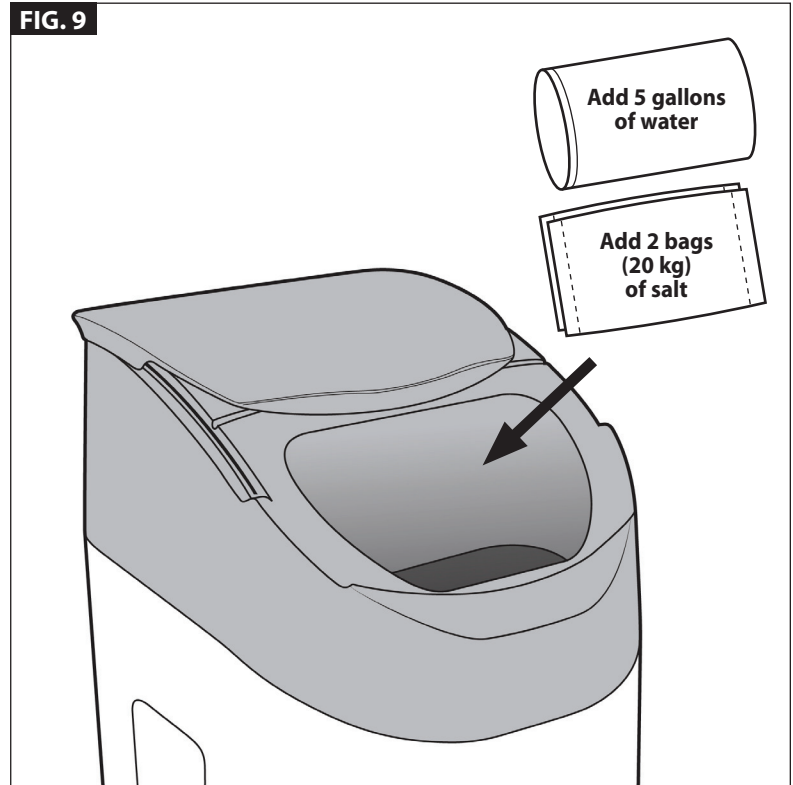
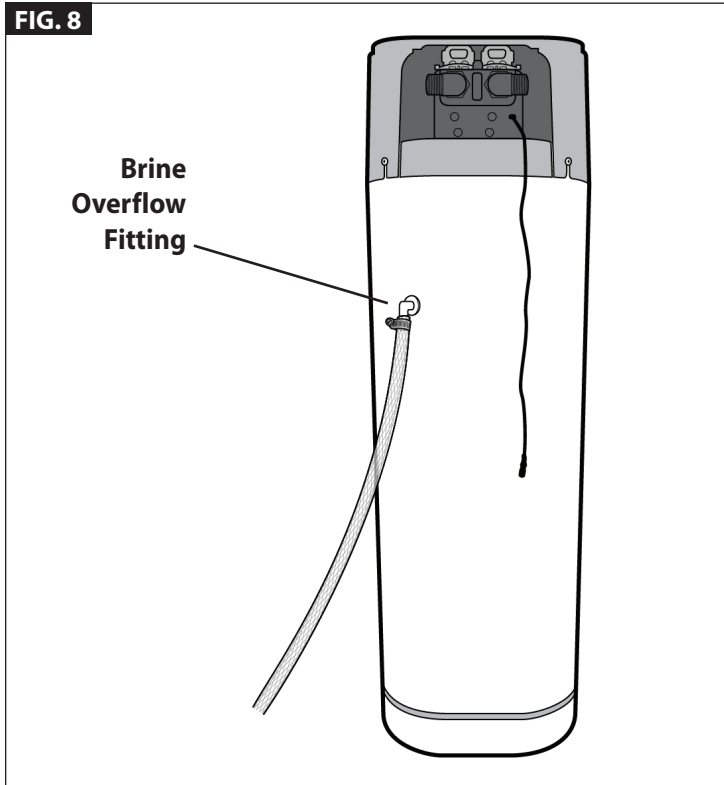

### Turn on the water supply

- Using the hex key (included), **turn the inlet valve SLIGHTLY (FIG. 10)** to service position (refer to FIG. 2A) to allow water to run **SLOWLY** into the unit. The water runs into the resin tank so you will not see it. The water should initially fill the resin tank slowly. This prevents resin from being pushed up into the control head by the initial surge of water going in. Once the resin tank is full of water, you can open the valve fully.
- Make sure there are no leaks in your plumbing before proceeding.
- Using the hex key, **SLOWLY** open the **outlet side** of the bypass valve (FIG. 11) and open a faucet for a few minutes or until the system is free of any air or foreign material resulting from the plumbing work. Close the water tap when water runs clean. **Note:** The water may be discoloured for the first few minutes. This is **NORMAL** and will clear up after a few gallons of water goes through.
- Connect the control valve cord to the power adaptor cord (FIG. 12) and connect the power adaptor to a 120 V AC 60 Hz outlet.

Proceed to **START-UP AND PROGRAMMING**.

**NOTE: Your unit is not yet ready for service until you complete START-UP AND PROGRAMMING (pages 8-11) and Manual Regeneration (page 11).**

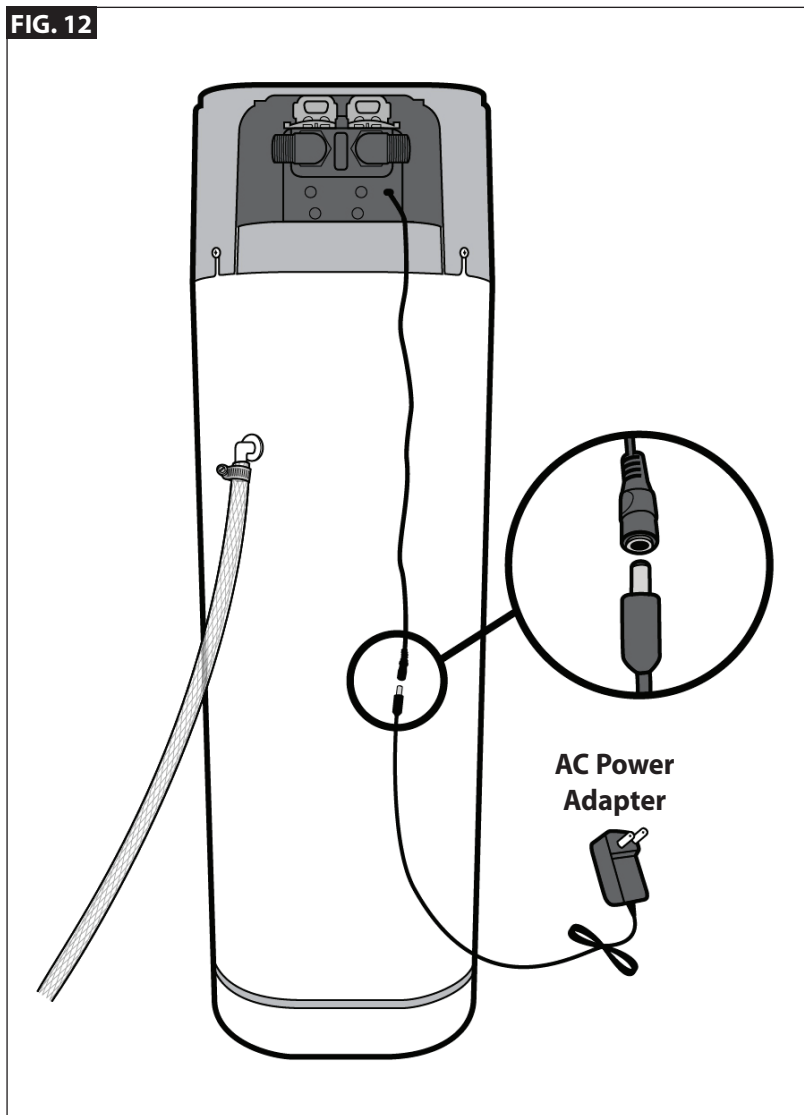
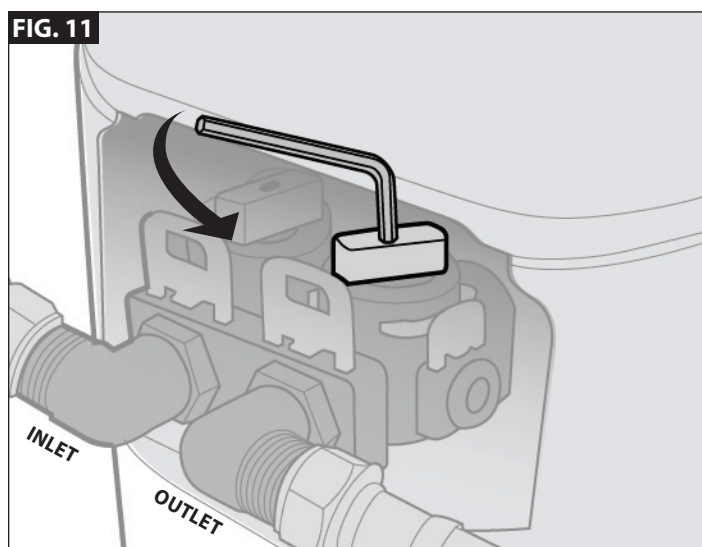
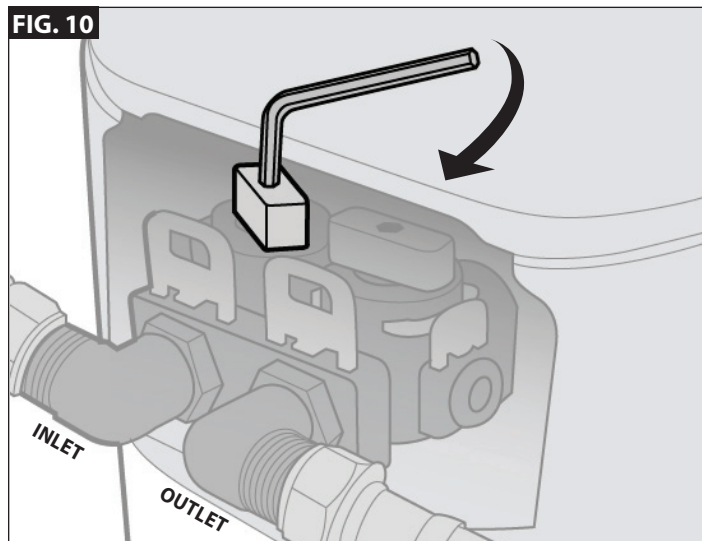

## E. START-UP AND PROGRAMMING

When the power is connected, the screen will show the following information in sequence:

1. Date and Time.
2. Total U.S. Gallons, Remaining U.S. Gallons.
3. People Reserve, Reserve U.S. Gallons.
4. Estimated days to regeneration.
5. Last regeneration — last date when system regenerated.
6. Total regenerations.
7. Total treated.
8. Overrun total.
9. Current Flow Rate (GPM) — flow rate of water being currently used.
10. Peak Flow Rate (GPM) — Maximum recorded flow rate of the water.
11. Day override.
12. Rinse override.
13. Delayed regeneration.
14. Regeneration Time — time of day when backwash starts.
15. Refill time.
16. Valve mode.
17. Valve ID.

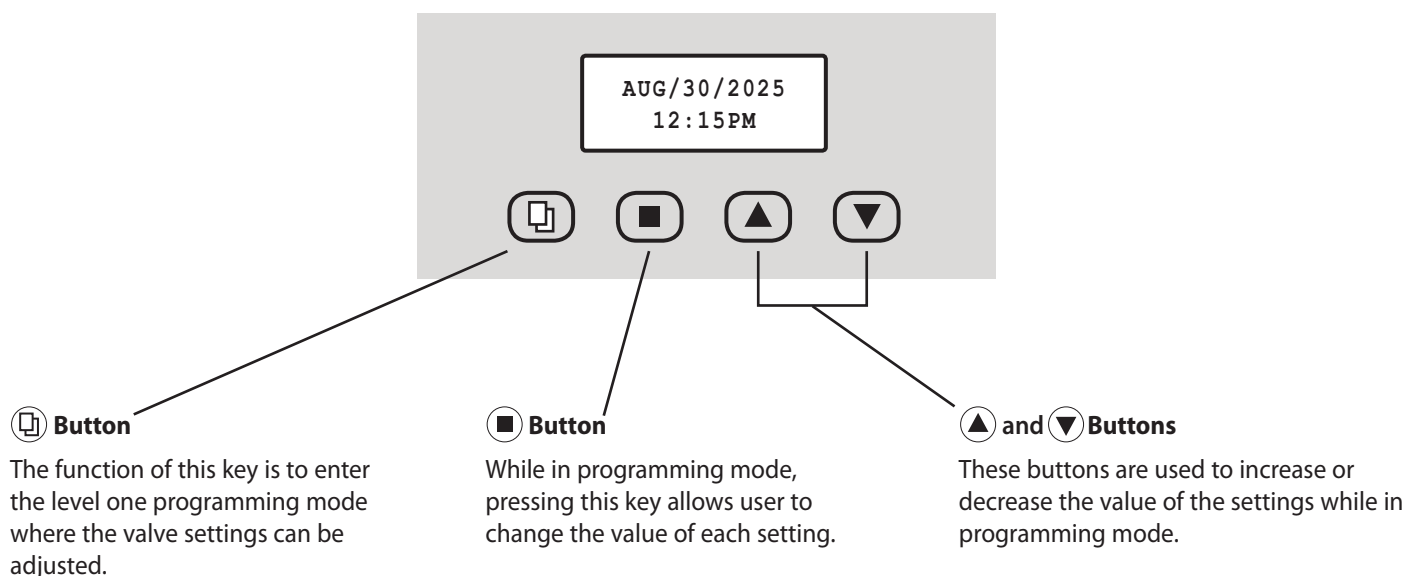

### STEP 1. LANGUAGE SELECTION

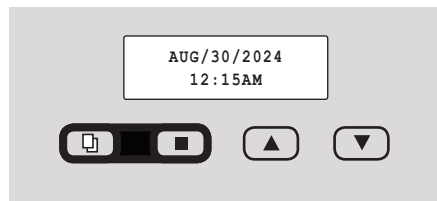

1. Press any button to start. Press and hold buttons **□** and **■** together until language setting appears on the display.



2. Use **▲** and **▼** to navigate to preferred language.

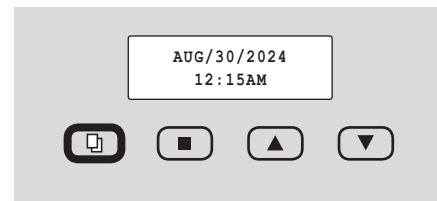

3. Press **□** to confirm selection.

## STEP 2. PROGRAM HOUSEHOLD SETTINGS

This unit is factory set for the correct size. You are required to program the date, the time of day, the number of people living in the home and the correct hardness setting. Please review Compensated Hardness Calculation before entering the hardness number from your water analysis.

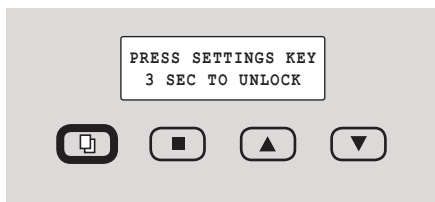

1. The display may read "**PRESS SETTINGS KEY**". Press for three seconds (3) to unlock.
2. After three (3) seconds, the display will beep confirming unlock.

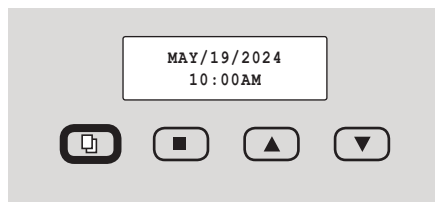

3. Press and hold for three seconds (3) until you hear a beep. This will unlock the **SETTINGS** menu.



4. Now press or to change the **HO**UR value to current time.



5. Press once to highlight the next value.



6. Now press or to change the **MINUTE** value to current time.

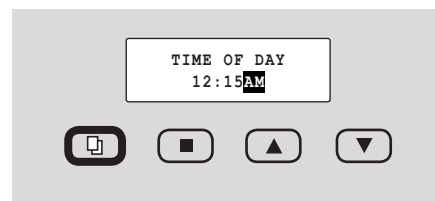

7. Press once to highlight the next value.



8. Now press or to change the **AM/PM** value to current time.



9. Press once to highlight the value.



10. Now press or to change the **YEAR** value to current year.

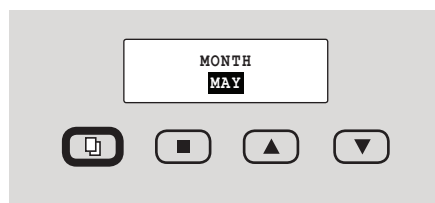

11. Press once to highlight the current month.



12. Now press or to change the **MONTH** value to desired month.



13. Press once to highlight day.

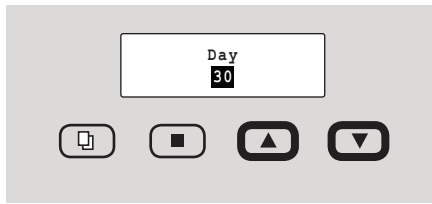

14. Now press ▲ or ▼ to change the **DAY** value to desired day.

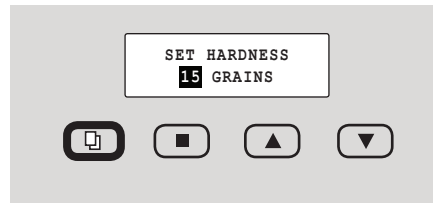

15. Press □ once to highlight SET HARDNESS value.

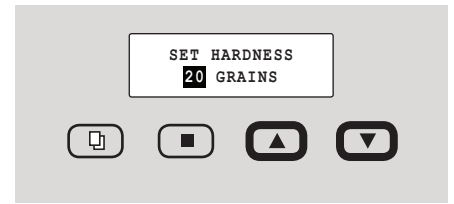

16. Now press button ▲ or ▼ to change **HARDNESS** value.  
**Note:** Add compensated water hardness value as below.

**Compensated Hardness:**

To calculate compensated hardness value, multiply ferrous iron and manganese concentration (in PPM) by 5 and 8 respectively, and add to hardness value.

For example, your water analysis report may indicate as follows:

Hardness = 15 Grains/gal

Iron = 0.5 PPM

Manganese = 0.05 PPM

In this example, compensated hardness =  $15 + (5 \times 0.5) + (8 \times 0.05) = 17.9 \text{ GPG}$

Enter this value under SET HARDNESS



17. Press □ once to highlight SET PEOPLE value.



18. Now press ▲ or ▼ to change # of **PEOPLE**.



19. Press □ once to highlight **SALT SETTING**. If water contains iron and manganese, change to **IRON+MN**.



20. Press □ once to highlight WATER SOURCE.



21. Now press ▲ or ▼ key to change **WATER SOURCE** value. For problem water set to **WELL/OTHER**. For clean, city water choose **MUNICIPAL**.

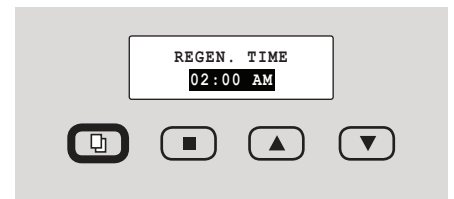

22. Press □ once to highlight value. Regen. time should be during a period of time with no water use such as overnight.



23. Now press ▲ or ▼ to change **REGEN. TIME**.

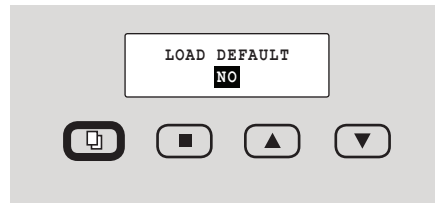

24. Now press □ once to highlight **LOAD DEFAULT**. **DO NOT** change this setting.

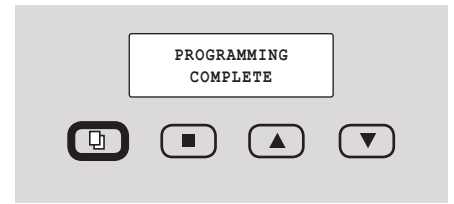

25. Press □ once to **COMPLETE PROGRAMING** household settings.

### STEP 3. DISINFECTING THE SOFTENER

It is possible that during shipping, storage and installing, bacteria can go into the unit. Therefore, as a good installation practice, it is recommended that the softener be disinfected prior to use. To disinfect, open the lid of the brine well (FIG. 13) in the salt tank and add approx. 3 tablespoons of fresh common household bleach. Replace lid and start an immediate regeneration. The sanitizing regeneration takes two (2) hours. Then, treated water is available for your use.

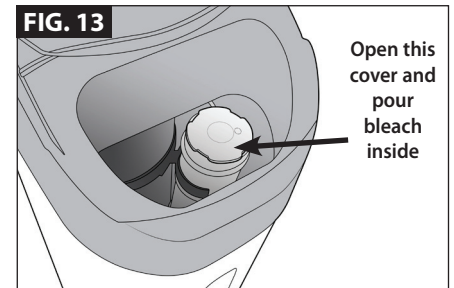

### STEP 4. MANUAL REGENERATION

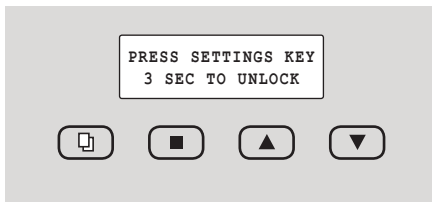

1. Press any button to start. The display may read **PRESS SETTINGS KEY 3 SEC TO UNLOCK** if left untouched for several minutes.

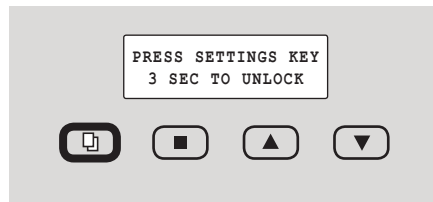

2. To unlock, press □ and hold for three (3) seconds. The display will beep confirming unlock.

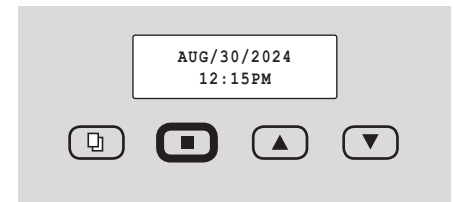

3. Press and hold ■ to start Manual Regeneration process.

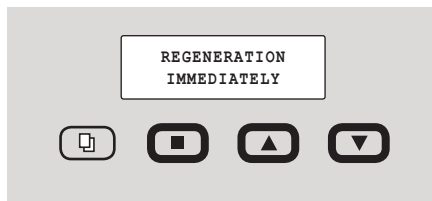

4. Press ▲ or ▼, choose **REGENERATION IMMEDIATELY**.  
5. Press ■ to start a regeneration cycle.



6. Valves will automatically start in backwash position.

7. Let the system run until regeneration is complete.  
8. Allow the unit to return to the SERVICE position.

**NOTE**  
If severe loss in water pressure is observed when the softener unit is initially placed in service, the softener tank may have been laid on its side during transit. If this occurs, backwash the softener to 'reclassify' the media.

## STEP 5. ADVANCED PROGRAMMING

This section is not necessary to complete the set-up. Valve settings have been preprogrammed for your convenience.

In the advanced programming, you can change individual regeneration cycle times. **DO NOT** change these without confirming with Rainfresh technical support. By changing these values your unit can malfunction.

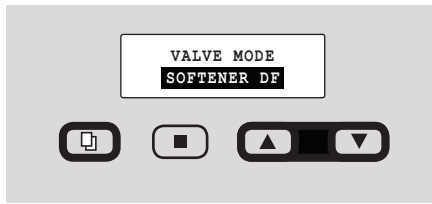

1. Unlock display by pressing for 3 sec. Press & keys **together** for 3 seconds until unit beeps and display changes to VALVE MODE.

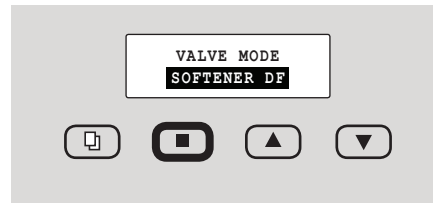

2. Leave VALVE MODE at default setting. Press button to advance to "SYSTEM SIZE".



3. Leave SYSTEM SIZE at default setting (RESIN VOL.). Press button to advance to "RESIN VOL".



4. For model 30C, RESIN VOL is 0.88 CF and for model 40C, it is 1.05 CF. Press button to advance to "SALT SETTING".

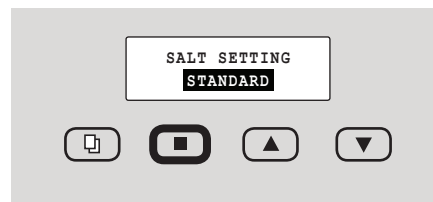

5. Leave at STANDARD (factory setting). If your water is clean and municipally treated, press or key to change the value to HIGH EFFICIENCY. Press button to advance to "BACKWASH".



6. Default BACKWASH is set for 5 min. Press to increase this setting if your water has high turbidity or iron.



7. Press button to advance to "BRINE".



8. Default brine is set for 53 min. You can use to increase this setting to max 70 min if your water has some iron.



9. Press button to advance to "RINSE".



10. Default RINSE is set for 4 min. You can use to increase this setting if you prefer a more thorough rinse.



11. Press button to advance to "REFILL". This is set to AUTO. Press to advance to LOCK VALVE.

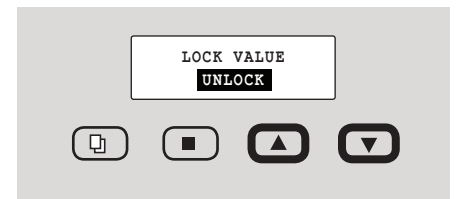

12. Press or key to either LOCK your settings or leave them unlocked.

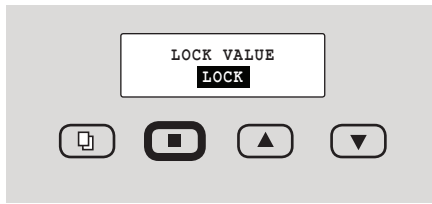

13. Press button to advance to complete programming.

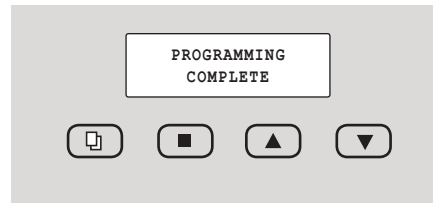

14. Display will briefly show PROGRAMMING COMPLETE and go to home screen. It will now display various settings in sequence.

## Congratulations!

### Start-Up Instructions are now complete – the unit is operational.

#### F. OPTIONAL PROGRAMMING

##### SETTING DAY OVERRIDE

Enabling the Day override feature means the softener will still follow the meter but if the softener hasn't regenerated in a set number of days, it will automatically regenerate regardless of the volume remaining. This is a good back-up to have in place to ensure the system regenerates regularly to keep the resin clean especially for situations where iron concentration exists or for homes where water consumption is very low. Typical override setting is 14 days.

##### SETTING SMART CLEAN

Smart Clean can be selected if you want to automatically have the system perform a short backwash and rinse cycle after seven (7) days of non-use. This helps prevent bacteria growth from stagnant water. This mode is also recommended for filters as certain types of filter media can 'cement' or harden during long periods of non-use. The factory setting for Smart Clean is off. If you are concerned about the extra water usage then leave Smart Clean OFF. With Smart Clean ON, the system will perform a ten (10) minute backwash every seven (7) days at the factory setting. This will use approximately fifteen (15) to fifty (50) gallons of extra water, depending on size of model.



1. To set DAY OVERRIDE, press and hold and together until you hear a beep.



2. Press until DAY OVERRIDE setting appears.



3. Press or to set the amount of Days required.

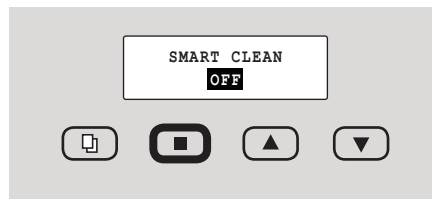

4. Press until SMART CLEAN setting appears.

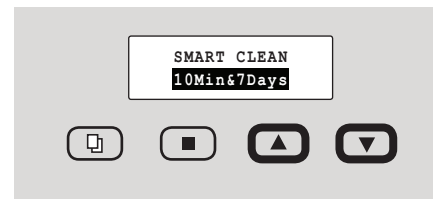

5. Press to enter minutes setting. Now press or to change Minutes. (Continued on next page)

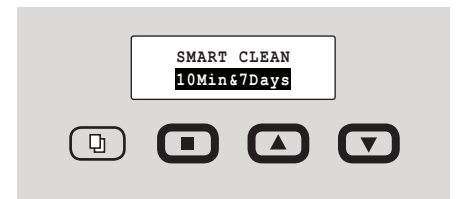

6. Press to enter Days setting. Now press button or to change Days. Press once to COMPLETE PROGRAMING.

## G. OTHER FEATURES

### Control Operation During a Power Failure

In the event of a power failure, the valve will keep track of the time and day for 48 hours. The programmed settings are stored in a non-volatile memory and will not be lost during a power failure. If power fails while the unit is in regeneration, the valve will finish regeneration after power is restored. If the valve misses a scheduled regeneration due to a power failure, it will queue regeneration at the next regeneration time once power is restored.

### Safety Float

The brine tank is equipped with a safety float which prevents your brine tank from overflowing as a result of a malfunction such as a power failure.

### New Sounds

You may notice new sounds as your water softener operates. The regeneration cycle lasts approximately 2 hours. During this time, you may hear water running intermittently to the drain.

### Manual Bypass

In the case of emergency, such as an overflowing brine tank, you can isolate your water softener from the water supply using the bypass valve located at the back of the control. To resume soft water service, open bypass valve by rotating the knobs counterclockwise.

## H. MAINTENANCE

Maintenance of your new water softener requires very little time or effort but is essential. Regular maintenance will ensure many years of efficient and trouble-free operation. Failure to follow maintenance instructions and schedule will result in the unit failing to operate properly and void your warranty.

### CARE OF YOUR SOFTENER

To retain the attractive appearance of your new water softener, occasionally clean it with a mild soap solution. Do NOT use abrasive cleaners, ammonia, or solvents.

### ADDING SALT TO THE BRINE TANK / CABINET

Use only clean salt labeled for water softener use, such as crystal, pellet, or nugget. The use of natural rock salt is discouraged because it contains insoluble silt and sand which buildup in the brine tank and cause problems with the system's operation.

- Put 40 kg [80 to 100 lbs] of water softener salt into the brine tank.
- Add the salt directly to the tank, filling it no higher than the top of the brine well. **Do NOT overfill the salt tank** as the additional weight of salt adds to the potential for salt bridging due to compaction.
- Check the salt level regularly. Remove the lid from the cabinet or brine tank. Ensure that the salt level is above the brine water level (FIG. 14).

### SALT BRIDGING

Humidity or poor-quality salt may create a cavity between the water and the salt. This action, known as 'bridging', prevents the brine solution from being made, and prevents your water from being conditioned. If you suspect salt bridging because of a lack of soft water or salt is NOT being consumed pour some warm water around the inside edges of the salt tank to break up the bridging. Allow four (4) hours to produce a brine solution, then manually regenerate the softener. This should always be followed by allowing the unit to use up any remaining salt and then thoroughly cleaning out the brine tank.

If you are unable to break the bridge this way, take a strong rod and carefully push down the salt, working it up and down (FIG. 15). Do not pound on the walls of the tank. If the wrong kind of salt is used, take it out and fill with nugget or pellet salt.

FIG. 14

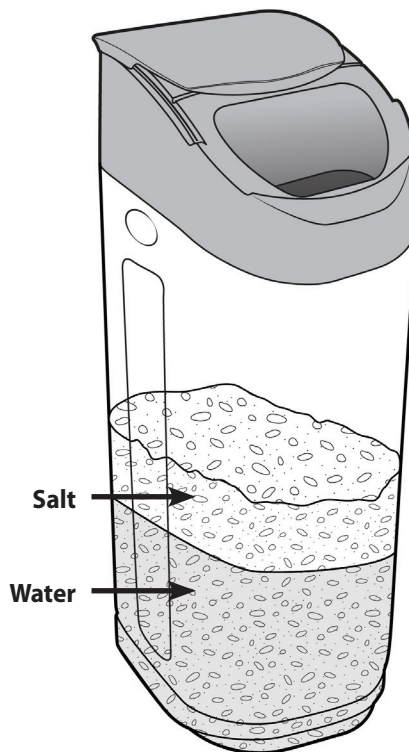

Ensure that the salt level is above the brine water level.

### CLEANING OF YOUR BRINE OR SALT TANK

Salt tanks will build up sludge (undissolved salt) in the bottom that increases over time. Every 2 – 3 years the salt tank(s) should be cleaned out and restarted using the original start-up instructions.

#### CAUTION

Liquid brine will irritate eyes, skin, and open wounds. Gently wash the exposed area with fresh water. Keep children away from your water softener.

#### NOTICE

Incorrect start-up, water above the salt level – not enough salt in tank – will affect the unit's capacity and result in hardness slippage. Should either of these situations happen, or the unit fails to regenerate for any other reason, correct the problem first, then regenerate the unit manually. Regenerate two times in a row to restore the reserve capacity and bring the media bed back up to specification.

### RESIN CLEANER

To maintain optimum performance of your softener, we highly recommend using RES CARE Resin Cleaner on a monthly basis, especially if your water supply contains iron. Follow the directions on the resin cleaner package.

### SERVICE SCHEDULE

- The injectors should be cleaned/inspected or replaced annually or as required depending on the water quality and use. See **Cleaning the Injector Assembly** (page 18).
- The seals and spacers along with the piston assembly should be inspected/cleaned or replaced annually or as required depending on the inlet water quality and water usage. See **Accessing the Powerhead and Replacing the Seals and Spacers** (page 16).
- Your inlet water quality and water consumption will determine how often the media should be replenished or replaced.

### SERVICING YOUR CONTROL VALVE

#### BEFORE SERVICING, YOU WILL NEED TO:

1. Shut the water supply to the softener OFF, put the softener into the BYPASS position.
2. Relieve water pressure in the softener by stepping the control into the backwash momentarily.
3. Return the control to the SERVICE position.
4. Unplug the electrical cord.
5. Disconnect the drain line connection.

**Always follow these steps prior to servicing the valve.**

#### CAUTION



#### RISK OF FLOOD

Disassembly while under pressure can result in flooding.

#### WARNING



#### RISK OF SHOCK

Unplug the unit before removing the cover or accessing any internal control parts.

FIG. 15

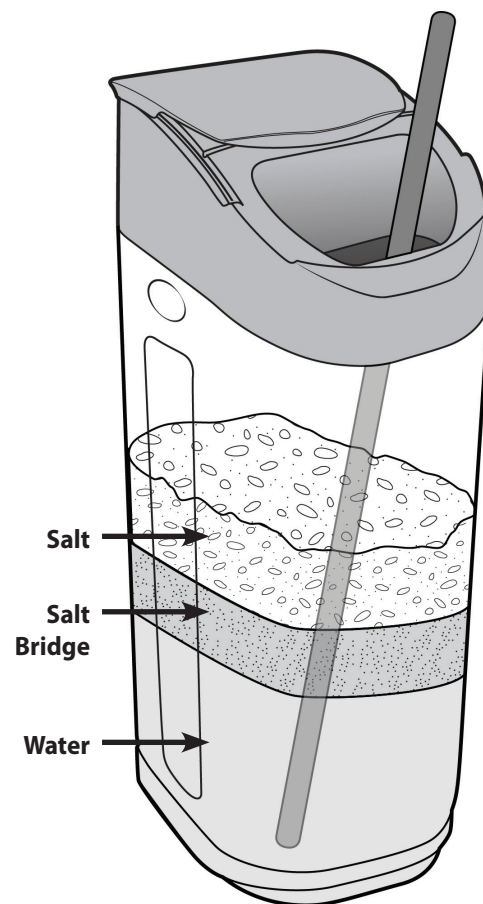

RES CARE  
Resin Cleaner -  
1 gal. Bottle

**SERVICING YOUR CONTROL VALVE (Continued)**  
**ACCESSING THE POWERHEAD AND REPLACING THE SEALS AND SPACERS**

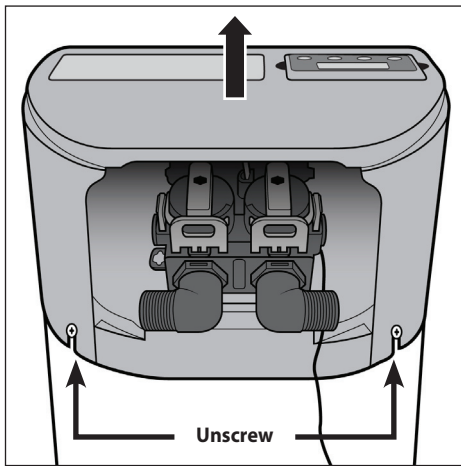

1. Unscrew the cabinet top using a screwdriver and place the top aside, making sure that the electronic cable underneath does not detach from the circuit board.

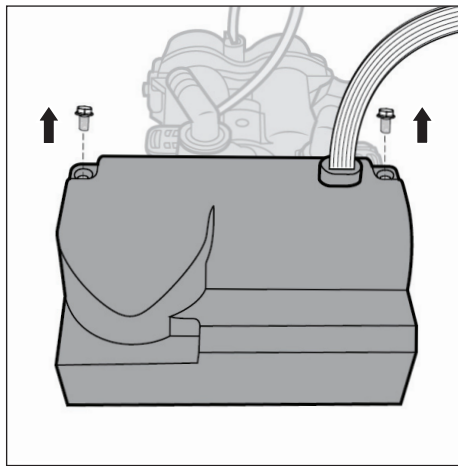

2. Remove the two (2) screws from control head lid.

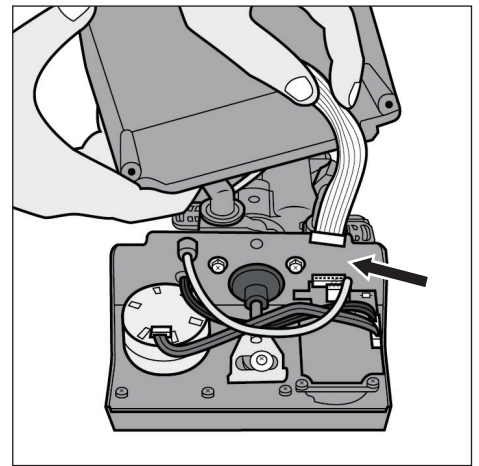

3. Remove the control head lid and carefully detach the electronic cable from the circuit board.

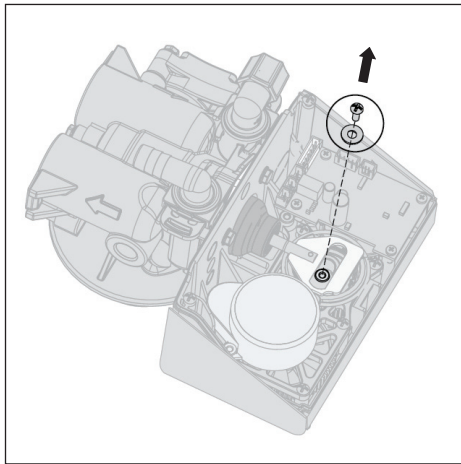

4. Remove screw and washer from piston rod link.

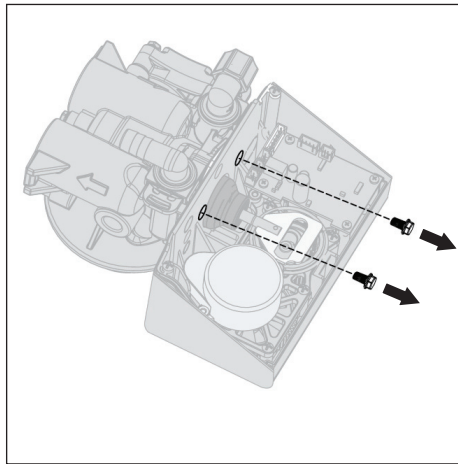

5. Remove two (2) bolts securing powerhead to body.

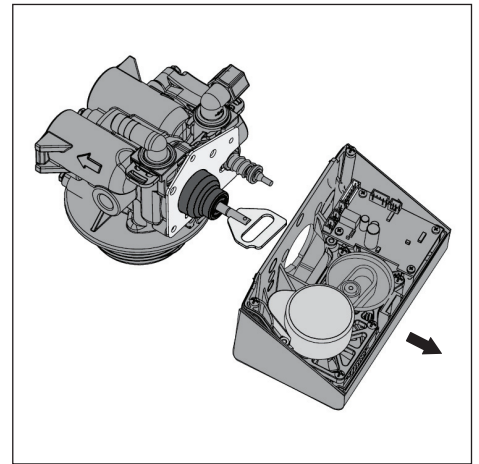

6. Remove powerhead from body.

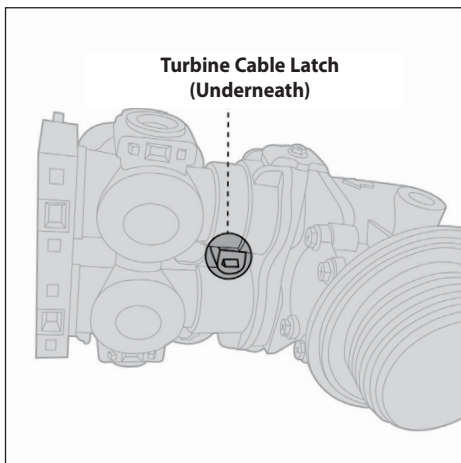

7. Release the turbine cable by pressing the latch on the underside of the control head.

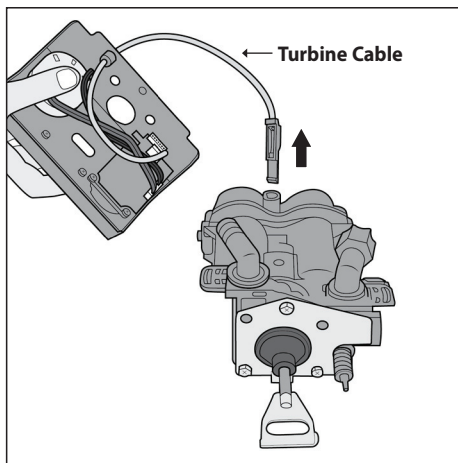

8. Slide the turbine cable out once released.

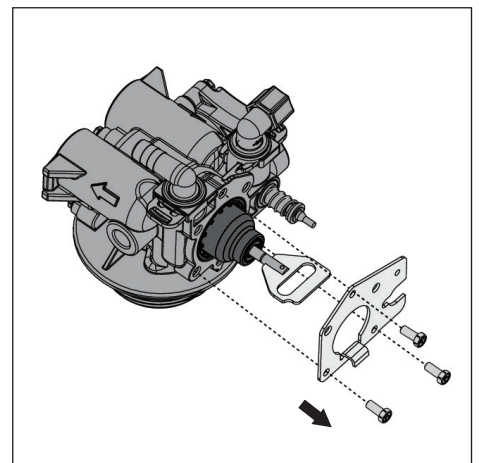

9. Remove the three (3) screws holding the plate, then remove the plate.

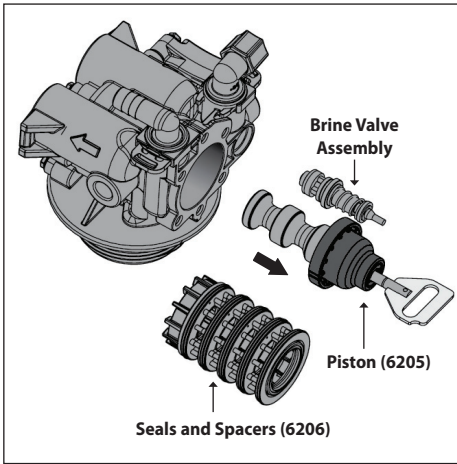

10. Remove the piston (6205), and ALL of the seals and spacers (6206). The brine valve assembly can also be removed in this stage.

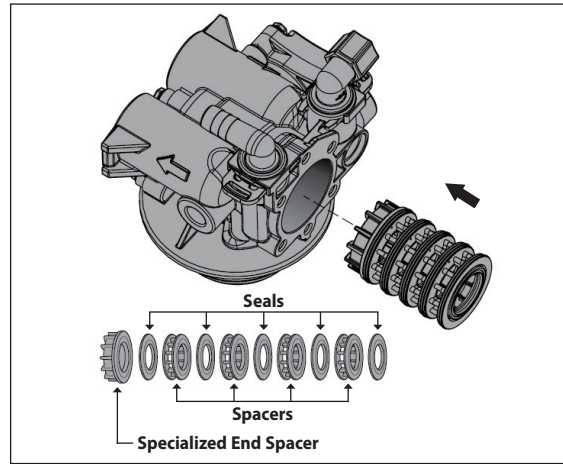

11. Very lightly lubricate seals so they are shiny. Insert new lubricated seals and spacers as shown. Important, use the specialized end spacer and note it's placement.  
**NOTE: Do NOT use petroleum-based grease products during replacement and assembly. Use only approved food grade silicone such as DOW 111 or equivalent.**

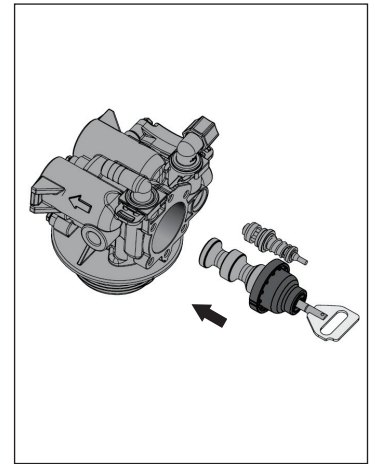

12. Insert the piston. Insert the brine valve assembly if removed in Step 10.

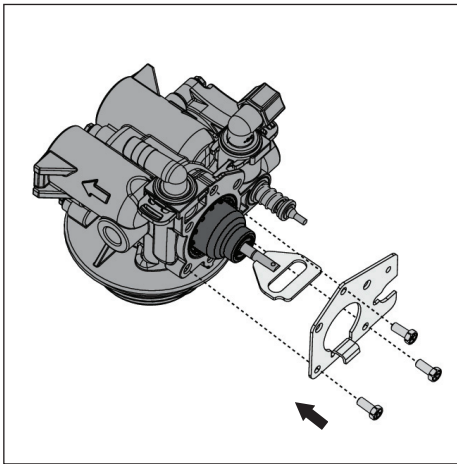

13. Reattach the plate and tighten the three (3) screws. **NOTE: Tighten screws equally in a criss-cross pattern so the plate compresses evenly.**

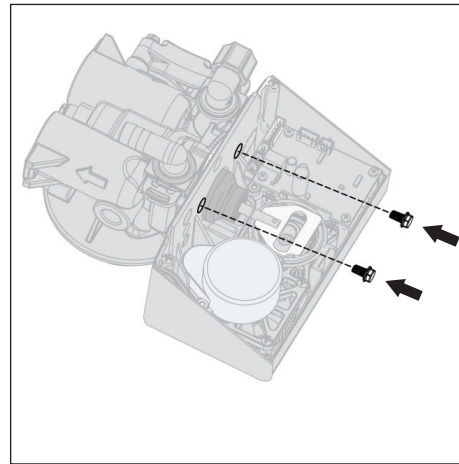

14. Reattach the control head and tighten the two (2) bolts securing powerhead to body.

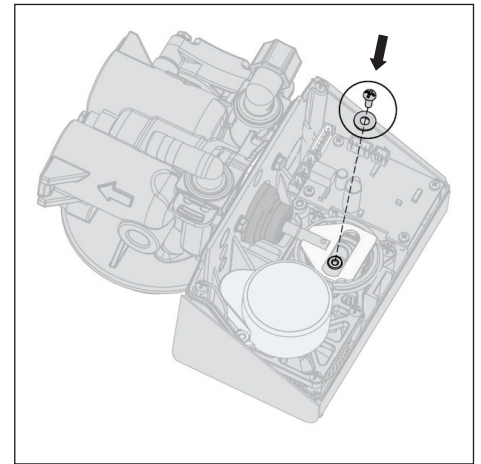

15. Reattach the screw and washer into the piston rod link. Tighten the screw — **do not overtighten.**

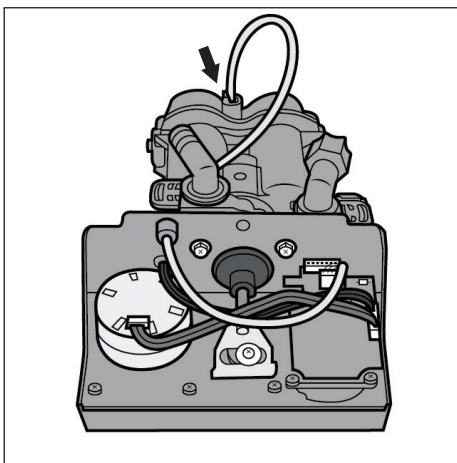

16. Fully insert the turbine cable back into it's slot — ensure the latch is secure underneath.

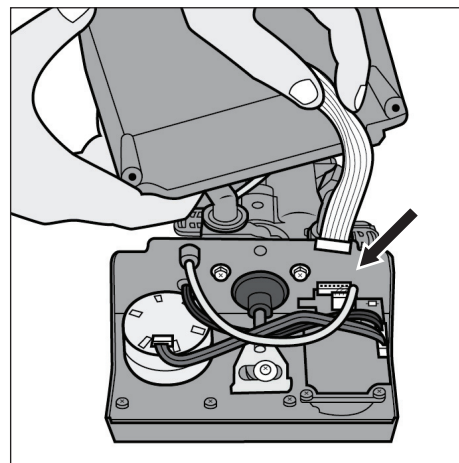

17. Connect the electronic cable to the circuit board.

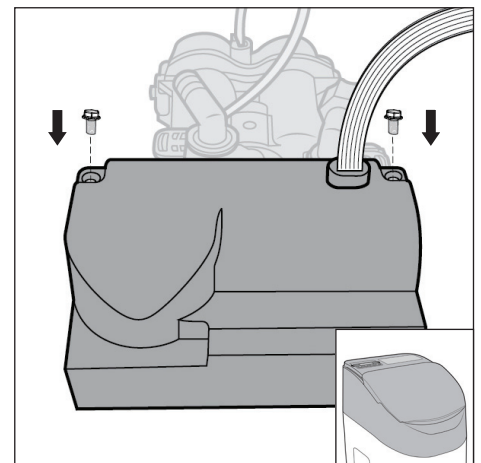

18. Screw in the two (2) screws for the control head lid and reattach the softener top. Tighten the screws on the back of the lid.

## Cleaning the Injector Assembly

Sediment, salt and silt will restrict or clog the injector causing malfunction of the unit. A clean water supply and pure salt will prevent this from happening. The injector assembly is located on the side of the control valve (FIG. 16), underneath the cabinet top. This assembly is easy to clean. Shut off the water supply to your softener and release the pressure by opening a cold soft water faucet. Using a screwdriver, remove the three screws holding the injector cover to the control valve body (FIG. A). Carefully remove the assembly and disassemble as shown in FIG. B. The injector nozzle is removed from the valve body by carefully turning it out with a large screwdriver. Remove the injector throat the same way. Carefully flush all parts including the screen. Use a mild acid such as vinegar to clean the small holes in the orifice and throat. Reassemble by reversing the procedure. During final assembly be sure the injector is seated correctly as shown in FIG. C.

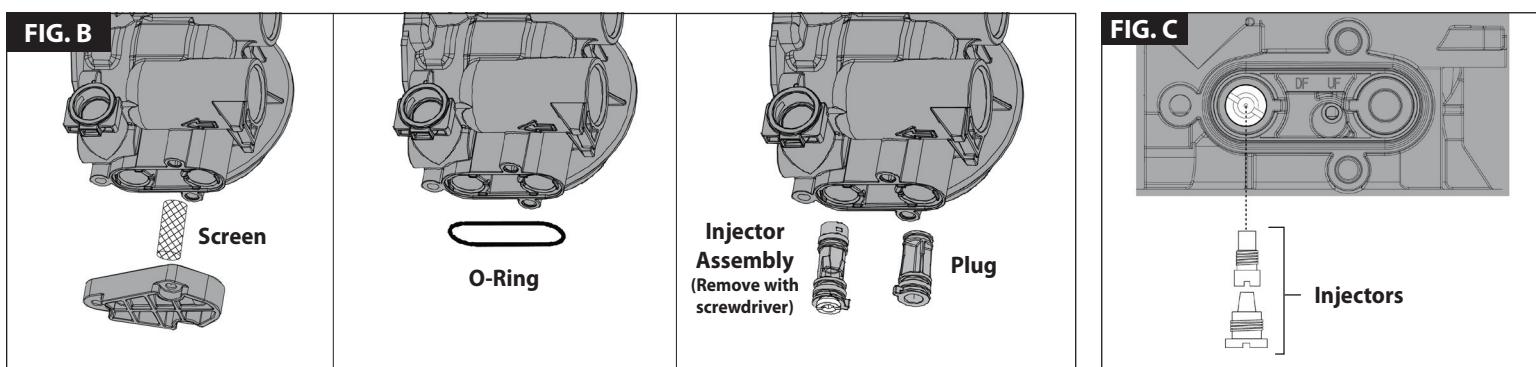
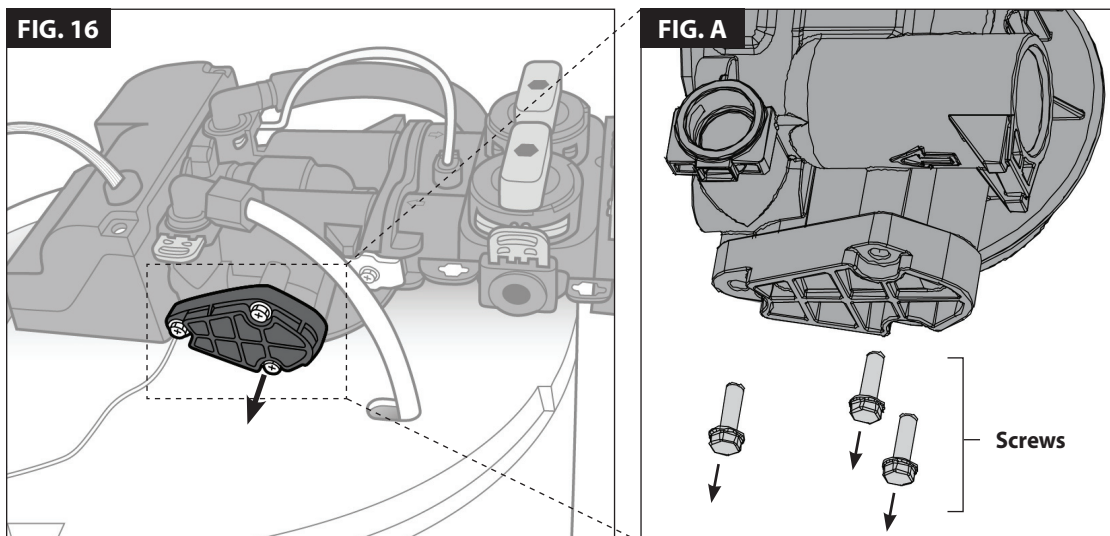

## I. TROUBLESHOOTING

ISSUE	POSSIBLE CAUSE	POSSIBLE SOLUTION
A. Unit fails to start a regeneration cycle	<ol style="list-style-type: none"> <li>1. No power supply</li> <li>2. Defective circuit board</li> </ol>	<ol style="list-style-type: none"> <li>1. Check electrical service and re-set time of day</li> <li>2. Replace faulty parts</li> </ol>
B. Water is hard	<ol style="list-style-type: none"> <li>1. Bypass valve is closed</li> <li>2. No salt in salt tank</li> <li>3. Plugged injector/screen</li> <li>4. Water hardness is set wrong</li> <li>5. Leak between valve and riser tube</li> <li>6. Internal valve leak</li> </ol>	<ol style="list-style-type: none"> <li>1. Open bypass valve</li> <li>2. Add salt to salt tank</li> <li>3. Clean parts (page 18)</li> <li>4. Correct hardness setting based on a water test</li> <li>5. Check if riser is cracked or O-ring is damaged. Replace faulty parts</li> <li>6. Replace valve seals, spacer and piston assembly</li> </ol>
C. Salt use is high	<ol style="list-style-type: none"> <li>1. Hardness setting is too high</li> </ol>	<ol style="list-style-type: none"> <li>1. Correct hardness setting based on a water test</li> </ol>
D. Low water pressure	<ol style="list-style-type: none"> <li>1. Iron or scale buildup in line feeding softener</li> <li>2. Iron buildup inside valve or tank</li> <li>3. Inlet of control valve plugged due to dirt</li> </ol>	<ol style="list-style-type: none"> <li>1. Clean/replace supply line</li> <li>2. Clean control valve and add resin cleaner to clean bed. Increase regeneration frequency</li> <li>3. Clean control valve inlet</li> </ol>
E. Resin in drain line	<ol style="list-style-type: none"> <li>1. Air in water system</li> <li>2. Incorrect or missing drain line flow control (DLFC)</li> </ol>	<ol style="list-style-type: none"> <li>1. Check well system for proper air elimination</li> <li>2. Check and replace DLFC</li> </ol>

F. Too much water in brine tank	<ol style="list-style-type: none"> <li>1. Plugged injector or screen</li> <li>2. Plugged brine valve</li> <li>3. DLFC plugged</li> </ol>	<ol style="list-style-type: none"> <li>1. Clean parts (page 18)</li> <li>2. Clean parts (page 17)</li> <li>3. Clean DLFC</li> <li>4. Replace seals/spacers (page 16)</li> </ol>
G. Unit fails to draw brine	<ol style="list-style-type: none"> <li>1. DLFC plugged</li> <li>2. Injector or screen is plugged</li> <li>3. Inlet pressure too low</li> <li>4. Internal valve leak</li> </ol>	<ol style="list-style-type: none"> <li>1. Clean DLFC</li> <li>2. Clean parts (page 18)</li> <li>3. Increase min pressure to at least 25 psi</li> <li>4. Replace seals, spacer and piston assembly (page 16)</li> </ol>
H. Unit cycles continuously	<ol style="list-style-type: none"> <li>1. Defective circuit board</li> </ol>	<ol style="list-style-type: none"> <li>1. Replace faulty parts</li> </ol>
I. Water flows to drain continuously	<ol style="list-style-type: none"> <li>1. Valve settings incorrect</li> <li>2. Internal leak</li> </ol>	<ol style="list-style-type: none"> <li>1. Check valve settings</li> <li>2. Replace seals, spacer and piston assembly (page 16)</li> </ol>

**Need help troubleshooting? Call Toll Free 1-800-667-8072 Monday to Friday 8:30 AM to 5 PM EST.**

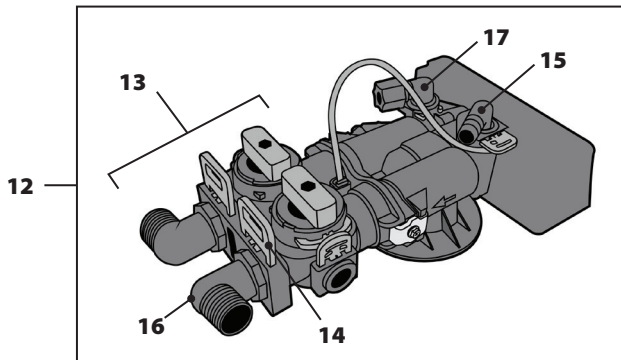
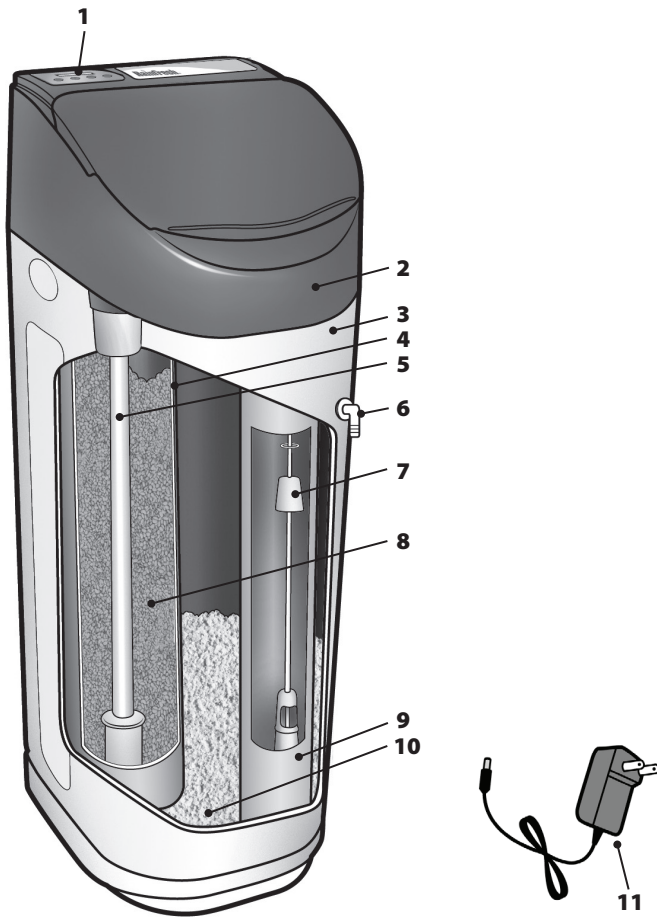

	<b>Description (Part No.)</b>
<b>1</b>	Control Valve Display Module
<b>2</b>	C Series Cabinet cover
<b>3</b>	C Series Cabinet
<b>4</b>	Media Tank for model 30C – 9"x 35"
	Media Tank for model 40C – 10"x 35"
<b>5</b>	Riser (6216)
<b>6</b>	Overflow fitting
<b>7</b>	Brine safety float (6210)
<b>8</b>	Resin (6064)
<b>9</b>	Brine Well
<b>10</b>	Salt (Not included)
<b>11</b>	Power adapter 110V (6203)
<b>12</b>	Control Valve (6200HE)
<b>13</b>	Bypass Assembly (6207)
<b>14</b>	Bypass Clips (6207-1)
<b>15</b>	Drain Fitting (6214-2)
<b>16</b>	Inlet / Outlet Fittings 3/4" MNPT (6208)
<b>17</b>	Brine Fitting (6209-1)

**To order replacement parts:**

**Call 1800 667 8072**

Monday to Friday  
8:00 AM to 5:00 PM EST

## J. LIMITED WARRANTY

This Rainfresh Water Softener System is warranted to the original Consumer purchaser for a period of ten (10) years, from the date of purchase, against defects in materials or workmanship. The electronic controls and mineral tank are warranted for five (5) and ten (10) years respectively against defects in materials or workmanship. The company's obligation under this warranty shall consist of repair or replacement, at its option, of any part (except for wear-and-tear items, e.g., resin media, piston, seals and brine valve) found by company inspection to be defective, provided that the product has not been misused, abused, altered or damaged by Consumer with respect to the original installation, as determined by the company. This warranty will not apply if water passing through the system has a) turbidity / suspended solids > 5 ppm (mg/L), b) hydrogen sulphide concentration greater than 0.05 ppm (0.05 mg/L), c) iron concentration greater than 0.5 ppm (0.5 mg/L) or manganese concentration greater than 0.05 ppm (0.05 mg/L), d) tannins or colour. This limited Warranty applies only to a unit when returned to the Warrantor at the owner's expense and in accordance with permission and shipping instructions received from the Warrantor. This warranty does NOT cover, and is intended to exclude, any liability on the part of the company for any incidental damages, consequential damages, labour charges or any other costs incurred in connection with the purchase, installation, use, maintenance or repair of the system whether under this warranty or any other warranty implied by law. Some provinces do not allow the exclusion of incidental or consequential damages, so the above limitation or exclusion may not apply to you. This warranty gives you specific legal rights and you may also have other rights, which vary from province to province. This warranty applies only to softeners purchased in Canada.



# Rainfresh®



**ENVIROGARD PRODUCTS LIMITED**

446 Major Mackenzie Dr. E., Richmond Hill, ON L4C 1J2 CANADA  
Help Line: 1-800-667-8072 • Toronto & Area: (905) 884-9388 • Web Site: [www.rainfresh.ca](http://www.rainfresh.ca)

© COPYRIGHT • ENVIROGARD PRODUCTS LIMITED 2026 • ALL RIGHTS RESERVED