

# ESS2/CALR

## COMMERCIAL WATER FILTER SYSTEM



### For high quality drinking water

Rainfresh COMFRESH system (model ESS2/CALR) is a premium drinking water system that reduces harmful suspended and dissolved contaminants from water. Designed for undersink installation, COMFRESH system delivers premium quality drinking water on demand for use in **office serveries, kitchens or cafeterias in multi-storeyed buildings.**

It incorporates a 2-stage filtration design that:

- Reduces chloramine, lead, VOC, THM, chemicals\*, chlorine and associated taste and odours and sediment
- Provides clean, fresh, crystal clear water on demand for drinking

With COMFRESH there is no need for expensive and environmentally wasteful water bottles.

\* The following chemicals are reduced by COMFRESH

**PROTECTS AGAINST**

- Chloramines
- Lead
- VOC
- Pesticides / herbicides
- Industrial Pollutants
- Chlorine, taste and odour
- Sediment

alachlor	1,2-dichloroethane	1,1,2,2,-tetrachloroethane	tetrachloroethylene
atrazine	1,1-dichloroethylene	heptachlor (H-34, Heptox)	toluene
benzene	cis-1,2-dichloroethylene	heptachlor epoxide	2,4,5-TP (silvex)
carbofuran	trans-1,2-dichloroethylene	hexachlorobutadiene	tribromoacetic acid
carbon tetrachloride	1,2-dichloropropane	hexachlorocyclopentadiene	1,2,4-trichlorobenzene
chlorobenzene	cis-1,3-dichloropropylene	lindane	1,1,1-trichloroethane
chloropicrin	dinoseb	methoxychlor	1,1,2-trichloroethane
2,4-D	endrin	pentachlorophenol	trichloroethylene
dibromochloropropane (DBCP)	ethylbenzene	simazine	xlenes (total)
o-dichlorobenzene	ethylene dibromide (EDB)	styrene	trihalomethanes (jncludes)
p-dichlorobenzene	haloacetonitriles (HAN) bromochloroacetonitrile dibromoacetonitrile dichloroacetonitrile trichloroacetonitrile	haloketones (HK) 1,1-dichloro-2-propanone 1,1,1-trichloro-2-propanone	chloroform (surrogate chemical) bromoform bromodichloromethane chlorodibromomethane



Provides filtered water equivalent of 4,500 bottles (500 mL) of water



## Installation

The COMFRESH system is designed for undersink or any other wall mounted remote location from where tubing can be run to the faucet. The unit should not be installed more than fifteen feet away from the faucet. The unit includes all fittings and parts required to make an undersink connection.

Included with the unit

- Unit to mount undersink or remotely
- Chrome ceramic-disc faucet (1/4 turn on/off)
- Set of 2 cartridges (model CA1G and LR1G)
- 3/8" OD supply tubing (5 ft) and 3/8" OD faucet tubing (5 ft)
- Supply valve for copper or PEX (1/2" x 1/2" x 3/8" compression)

## Faucet Choices

COMFRESH System includes a quarter-turn polished chrome ceramic disc faucet and all fittings and tubing necessary to install the unit. Optional designer polished chrome, brushed nickel and oil rubbed bronze finishes are also available. Faucet finish should be specified with the order.



## System Dimensions

Model	Unit Width	Unit Height	Unit Depth
ESS2/CALR*	11" (279.4 mm)	15" (381 mm)	5.25" (133.4 mm)

- \* - a) For cold water use only. This product is for commercial use only.  
b) Do not use with water that is microbiologically unsafe or of unknown quality without adequate disinfection before or after the system.

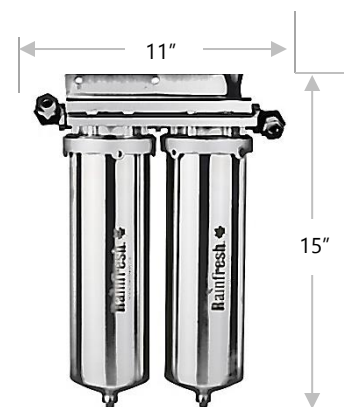

## Operating Specifications

Filter Cartridge Models : CA1G (pre-filter), LR1G (post-filter)  
Rated Capacity : 600 US gal<sup>^</sup> - (2,271 L)  
Inlet/Outlet Connections: 3/8"  
Max. Service Flow Rate : 0.75 US GPM (2.83 LPM)  
Max. Temperature : 100 F (38°C)  
Max. Pressure : 150 psi (1034 kPa)\*\*

<sup>^</sup> Cartridge life may vary with water quality and usage.

\*\* If pressure surges or water hammer conditions exist, a pressure regulator and/or water hammer arrestor should be installed.

Limited 1 year warranty

Oct 2019



## Envirogard Products Limited

446 Major Mackenzie Drive East,  
Richmond Hill, ON L4C 1J2, CANADA

Toll-free: 1 800 667 8072 ; Tel: (905) 884 9388; Fax: (905) 884 3532

E-Mail: [info@rainfresh.ca](mailto:info@rainfresh.ca) ; Web: [www.rainfresh.ca](http://www.rainfresh.ca)